

SAGE SRP SPECIFICATIONS

REMOTE STYLE INDUSTRIAL IN-LINE MASS FLOWMETER

Flow Meter is thermal dispersion type, utilizing constant temperature difference method of measuring Gas Mass Flow Rate. It contains two reference grade platinum RTD sensors clad in a protective 316 SS sheath. Features direct Mass Flow for gases, wide rangeability, low pressure drop, very low end sensitivity, and no moving parts.

Flow Meter is microprocessor based, does not have any potentiometers, and has Modbus® RS485 RTU communications (IEEE 754). Flow Meter is powered by 24 VDC (12 VDC optional or 115/230 VAC). The power dissipation is under 2.5 watts (e.g. under 100 ma at 24 VDC). Power and output terminals are in a separate compartment for ease of installation.

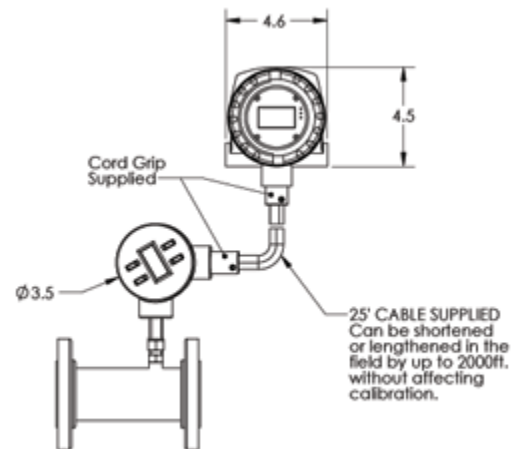

Electronics is Remote Style, with rugged windowed dual compartment enclosure with display. The display is a high contrast photo-emissive OLED display, and it displays Mass Flow Rate, Totalized Flow and Temperature as well as a graphical representation of Flow Rate in a horizontal bar graph format. In addition, the calibration milliwatts (mw) is continuously displayed, providing ongoing diagnostics. Flow meter provides a 4 to 20 ma output (ground based) proportional to Mass Flow Rate as well as Pulsed Outputs of Totalized Flow (24 VDC solid state transistor drive).

Flow Element is In-Line Style consisting of a choice of 316 Stainless Steel Schedule 40 Flow Bodies sized from ¼" x 6" long to 4" x 12" long. Male NPT ends are standard, with flanged ends, tube, or butt weld optionally available. Note 3" and 4" Flow Bodies have flanged ends as standard.

Flow Element's Junction Box is Explosion Proof (Class 1, Div 1, Groups B, C, D), and does not have any electronics – only a wiring terminal block. The Flow Element will be connected to the Electronics by 25 feet of lead-length compensated cable. The cable (6-conductor) can be lengthened or shortened without affecting accuracy (max loop resistance 10 ohms, over 1000 feet).

Calibration Self Check: Flow Meter has built in diagnostics – a display of the calibration milliwatts (mw) can be used to check the sensor's operation by being compared to the original reported "zero flow" value noted on last line of meter's Certificate of Conformance.

Accuracy is +/- 0.5% of Full Scale +/- 1% of reading with a turn-down of 100 to 1 and a resolution of up to 1000 to 1. Repeatability will be 0.2%. The Flow Meter is Sage Metering, Inc. SRP Series, with the trade name Sage Prime™.