



Sage Integral Prime Insertion Style, 230VAC Power

Specifications

Wetted Parts: 316L SS Wetted parts, C267 Hastelloy Options Available
Process Temperature: Standard -40° to 200°F, Optional to 300° F and 450° F
Pressure Rating: 500psig, 1000psig Optional
Accuracy: +/- ½ % of Full Scale +/- 1% of Reading
Repeatability: 0.2%

Outputs: 4-20mA (Flow), 24VDC Pulse (Total)
Digital Communication: Modbus RS485/RTU
User Supplied Power: 230VAC (100-230V~, 50/60Hz)
Enclosure: Nema 4, Powder Coated Aluminum
Electronics Temp Rating: -40° to 150° F (-40° to 66° C)

Model Number

(Example: SIP-05-06-AC230-CO2)

SIP---AC230-

Prope Lengths

Code	Ⓛ	Code	Ⓛ
1/2" Diameter		3/4" Diameter	
05-06	6" (152 mm)	07-06	6" (152mm)
05-12	12" (305 mm)	07-12	12" (305mm)
05-15	15" (381 mm)	07-15	15" (381mm)
05-18	18" (457 mm)	07-18	18" (457mm)
05-24	24" (610 mm)	07-24	24" (610mm)
05-30	30" (762 mm)	07-30	30" (762mm)
05-36	36" (914 mm)	07-36	36" (914mm)
		07-48	48" (1219mm)

Gas

Code		Code	
AIR	AIR	CL2	CHLORINE
N2	NITROGEN	CO	CARBON MONOXIDE
NG	NATURAL GAS	HE	HELIUM
CH4	METHANE	H2	HYDROGEN
PROPANE	PROPANE	DIG GAS	DIGESTER GAS
BUTANE	BUTANE	BIOGAS	BIOGAS
NH3	AMMONIA	LFG	LANDFILL GAS
CO2	CARBON DIOXIDE	FLARE GAS	FLARE GAS
AR	ARGON	FLUEGAS	FLUEGAS
O2	OXYGEN	MIX	MIXTURE
O3	OZONE		

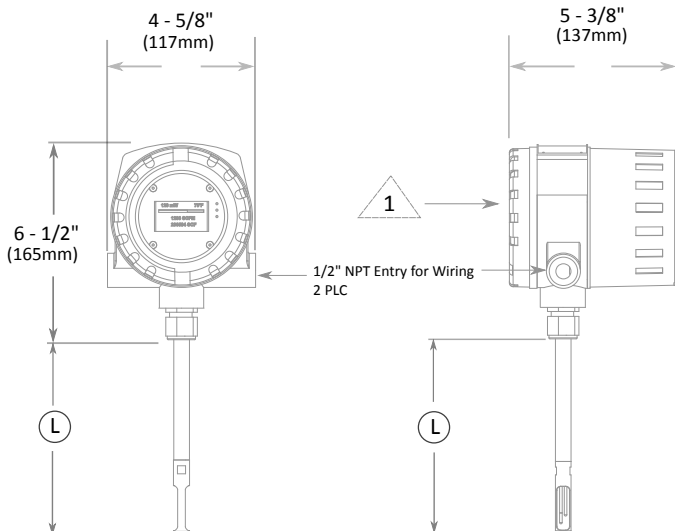

1 Basic Wiring Diagram

