



Sage Integral Prime In-Line Style With Flanged End Connections 115 VAC Power

Specifications

Wetted Parts: 316L SS Wetted parts, C267 Hastelloy Options Available
Process Temperature: Standard -40° to 200°F, Optional to 300° F and 450° F
Pressure Rating: 500psig, 1000psig Optional
Accuracy: +/- 1/2 % of Full Scale +/- 1% of Reading
Repeatability: 0.2%

Outputs: 4-20mA (Flow), 24VDC Pulse (Total)
Digital Communication: Modbus RS485/RTU
User Supplied Power: 115VAC (100-230V~, 50/60Hz)
Enclosure: Nema 4, Powder Coated Aluminum
Electronics Temp Rating: -40° to 150° F (-40° to 66° C)

Flanged Ends: 150 Class, ANSI, Raised Faced (ASTM A182 and ANSI/ASME B16.5)

Model Number

(Example: SIP-050-S150FLG050-AC115-CO2)

SIP- -AC115-

Flow Bodies

Code	D	L	H	BD Number and Diameter of Holes
050-S150FLG050	1/2" (15mm)	7" (177.8mm)	10.24" (260mm)	4 - 0.62" (16mm)
075-S150FLG075	3/4" (20mm)	7" (177.8mm)	10.35" (263mm)	4 - 0.62" (16mm)
100-S150FLG100	1" (25mm)	8" (203.2mm)	10.47" (266mm)	4 - 0.62" (16mm)
125-S150FLG125	1-1/4" (32mm)	10" (254mm)	10.65" (271mm)	4 - 0.62" (16mm)
150-S150FLG150	1-1/2" (40mm)	12" (304.8mm)	10.77" (274mm)	4 - 0.62" (19mm)
200-S150FLG200	2" (50mm)	12" (304.8mm)	11.00" (279mm)	4 - 0.75" (19mm)
250-S150FLG250	2-1/2" (65mm)	12" (304.8mm)	11.25" (286mm)	4 - 0.75" (19mm)
300-S150FLG300	3" (80mm)	12" (304.8mm)	11.57" (294mm)	4 - 0.75" (19mm)
400-S150FLG400	4" (100mm)	12" (304.8mm)	12.07" (307mm)	8 - 0.75" (19mm)

Gas

Code	Code	Code	Code
AIR	AIR	CL2	CHLORINE
N2	NITROGEN	CO	CARBON MONOXIDE
NG	NATURAL GAS	HE	HELIUM
CH4	METHANE	H2	HYDROGEN
PROPANE	PROPANE	DIG GAS	DIGESTER GAS
BUTANE	BUTANE	BIOGAS	BIOGAS
NH3	AMMONIA	LFG	LANDFILL GAS
CO2	CARBON DIOXIDE	FLARE GAS	FLARE GAS
AR	ARGON	FLUEGAS	FLUEGAS
O2	OXYGEN	MIX	MIXTURE
O3	OZONE		

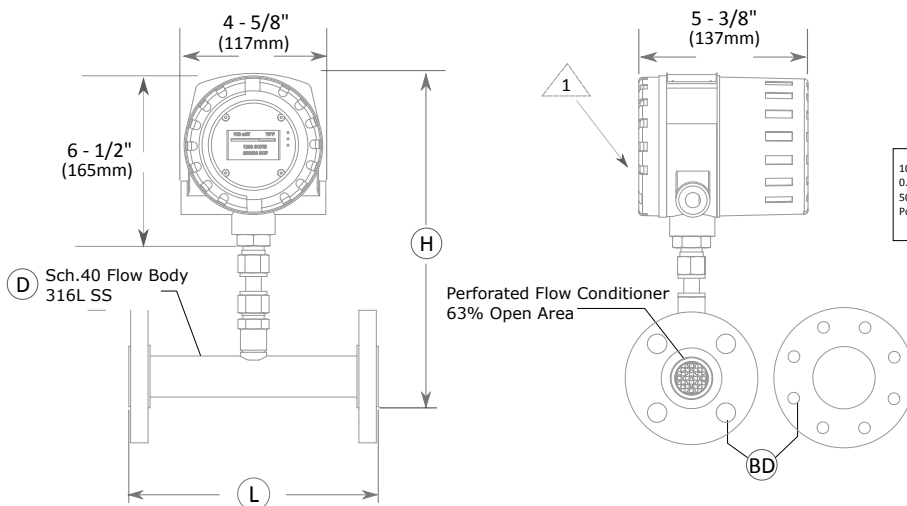

1 Wiring Diagram

