



SAGE THERMAL MASS FLOW METER
200/300 Series
USER MANUAL



SAGE METERING, INC.
8 Harris Court, Bldg. D
Monterey, CA 93940
866-677-SAGE (7243)
831-242-2030
SageMetering.com



Table of Contents

Quick Start Guide	5
Welcome	7
SECTION A: Getting Started	8
Unpacking Your Sage Meter	9
Maintenance	9
Calibration.....	9
Installation and Mounting.....	10
EN60079-14 Standard for Electrical Installations	10
Locating Proper Wiring Diagram.....	10
Insertion Flow Meter Application	11
Flow Profile and Installation Considerations	11
Sage Valve Assembly Operation	11
Flow Conditioning and Straight Run	11
Compression Fitting Operation.....	12
Captive Flow Conditioners	13
Probe Insertion Guideline	14
Installation Depth.....	14
Installation Depth Chart.....	15
Large Duct or Stack Applications	16
Inline Flow Meter Application.....	17
Electrical Wiring	18
Input Power.....	18
Output Wiring	19
SECTION B: Styles and Features	21
Principle of Operation of the Thermal Mass Flow Meter	22
Features and Benefits	23
Sage 200/300 Styles and Specifications (option 1)	24
Sage Display	26
Approvals	27

Hazardous Location Approvals..... 27

SECTION C: Drawings..... 28

 200/300 Series Integral Style Mass Flow Meters..... 29

 Inline Style^{1,3} 29

 Insertion Style² 29

 Mounting Hardware³ 30

 SVA05 Series Isolation Valve Assembly for Insertion Meters⁴ 30

 SVA05 Series Isolation Valve Assembly Detail 30

 STCF Series Teflon Ferrule Compression Fitting 30

 Mounting Plate for Thin-Walled Ducts 30

 SVA05LP Low-Pressure Isolation Valve Assembly..... 31

 Flanged Ends 32

 Flanged Mounting 32

SECTION D: Diagnostics..... 33

 Common Diagnostics 34

SECTION E: Warranties and Service Work 37

 Limited Warranty 38

 General Terms and Conditions..... 38

 Cancellation/Return Policy..... 38

 Returning Your Sage Meter..... 40

 RMA (Return Merchandise Authorization) 41

SECTION F: MODBUS..... 42

 Modbus Register Listing..... 43

 Sage Metering Modbus Protocol Rev. 1.80–Rev. 2.07 44

 Message Framing 44

 Address Field 44

 Function Code Field 44

 Data Field 44

 CRC Field 44

 Function Codes..... 45

 16 (0x10) Write Registers..... 46

 Query..... 46

 Sage Register Index Values 47

Example Modbus Packet..... 47

 Query..... 47

Sage Register Output Format..... 48

 Integer Representation 48

 IEEE754 Floating Point 48

 Scaled Decimal Representation 48

 SageCom Software 48

 Sage Technical Assistance 48

Registers Viewable from SageCom “Print SMB Data” 49



SECTION G: Appendix..... 50

 Correction Factors for Variation from Original Digester Gas Calibration 51

 Installations Where Pipe Condensation May Develop 51

 What is a Thermal Mass Flow Meter? 52

Quick Start Guide

Step	Description	P & ID Diagram																							
<p>1</p>	<p>PACKAGE CONTENTS:</p> <p>Ascertain that your order has all equipment and accessories; refer to the packing list.</p>	 <p>The image shows a 'PACKING LIST' form from Sage Metering, Inc. with fields for customer information, order details, and a table of items. To the right is a photograph of a Sage 200 flow meter, which is a circular device with a green body and a gold-colored faceplate.</p>																							
<p>2</p>	<p>INSERTION-TYPE FLOW METER DIAMETER CHECK:</p> <p>Check that the internal pipe diameter (ID) matches the pipe ID shown on the Sage Calibration Certificate.</p>	 <p>The image is a 'PRODUCT QUALITY CERTIFICATE OF CONFORMANCE' from Sage Metering, Inc. It includes a quality statement, a conformance statement, and a detailed paragraph certifying the instrument's compliance with ANSI/NCSL 2540 and ISO/IEC 17025 requirements. The certificate is signed and dated.</p>																							
<p>3</p>	<p>FLOW DIRECTION:</p> <p>Verify the straight-run requirements based upon pipe ID and meter type style.</p>	 <p>The image is a table titled 'IMPORTANCE OF FLOW CONDITIONING Recommended Pipe Diameters Upstream'. It compares 'Without Flow Conditioning' (Minimum Industry Recommendation) and 'With Flow Conditioning' (Sage Recommendation) for various pipe disturbances. A footnote explains that the 'With Flow Conditioning' column applies to in-line flow meters and insertion meters with upstream Captive Flow Conditioners.</p> <table border="1"> <thead> <tr> <th rowspan="2">DISTURBANCE</th> <th>Without Flow Conditioning</th> <th>With Flow Conditioning¹</th> </tr> <tr> <th>Minimum Industry Recommendation</th> <th>Sage Recommendation</th> </tr> </thead> <tbody> <tr> <td>One 90° Elbow</td> <td>25</td> <td>3</td> </tr> <tr> <td>Two 90° Elbows in the Same Plane</td> <td>36</td> <td>5</td> </tr> <tr> <td>Two 90° Elbows in Different Planes</td> <td>62</td> <td>9</td> </tr> <tr> <td>4:1 Area Reduction</td> <td>18</td> <td>3</td> </tr> <tr> <td>4:1 Area Expansion</td> <td>84</td> <td>10</td> </tr> <tr> <td>Multiple Disturbance</td> <td>TBD</td> <td>TBD</td> </tr> </tbody> </table> <p>¹ This column applies to in-line flow meters, which come standard with built-in flow conditioners, as well as insertion meters, when installed with upstream Captive Flow Conditioners.</p>	DISTURBANCE	Without Flow Conditioning	With Flow Conditioning ¹	Minimum Industry Recommendation	Sage Recommendation	One 90° Elbow	25	3	Two 90° Elbows in the Same Plane	36	5	Two 90° Elbows in Different Planes	62	9	4:1 Area Reduction	18	3	4:1 Area Expansion	84	10	Multiple Disturbance	TBD	TBD
DISTURBANCE	Without Flow Conditioning	With Flow Conditioning ¹																							
	Minimum Industry Recommendation	Sage Recommendation																							
One 90° Elbow	25	3																							
Two 90° Elbows in the Same Plane	36	5																							
Two 90° Elbows in Different Planes	62	9																							
4:1 Area Reduction	18	3																							
4:1 Area Expansion	84	10																							
Multiple Disturbance	TBD	TBD																							

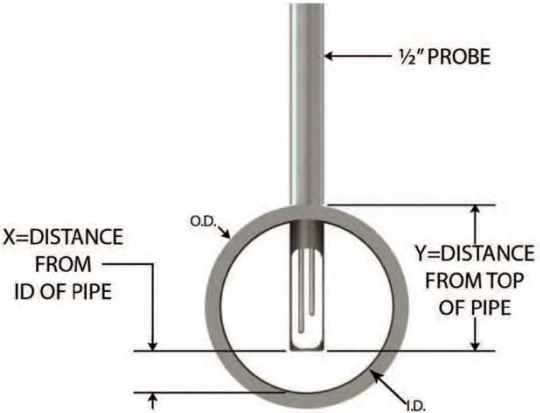
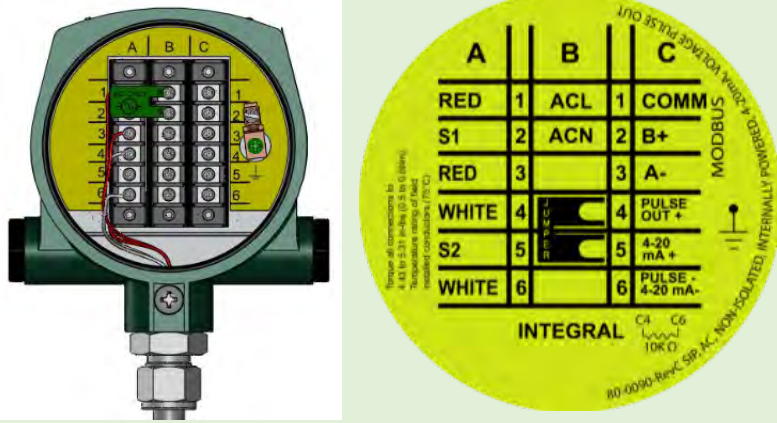
<p>4</p>	<p>VERIFY CORRECT PROBE DEPTH SETTING:</p> <p>1/2-Inch Probe</p> <p>See 1/2" Probe Diameter Installation.</p>	
<p>5</p>	<p>POWER SOURCE and 4-20mA WIRING:</p> <p>Remove the flow meter back cover and verify the wiring connectivity.</p>	

Welcome

We are pleased that you have purchased a Sage Metering Mass Flow Meter for your requirement. We hope you are satisfied with the performance, operation, and design of our precision NIST- traceable thermal gas mass flow meter.

Sage Metering is your source for monitoring, measuring, and controlling the gas mass flow in your industrial process, building management system, or environmental application. Our high-performance, NIST Traceable, thermal mass flow meters help increase productivity, reduce energy costs, maximize product yields, and help reduce environmental insult. Sage provides high-quality in-line and insertion thermal mass flow meters for a wide variety of industrial, commercial, and environmental monitoring needs, including carbon credit verification for greenhouse gas reduction.

Sage meters measure mass flow directly—there is no need for ancillary instrumentation such as temperature or pressure transmitters. Furthermore, our instruments have exceptional signal sensitivity, have no moving parts, require little if any maintenance, have negligible pressure drop, have a turndown up to 100 to 1, and resolve as much as 1000 to 1. Sage Flow Meters can measure the mass flow rate and consumption of air, oxygen, natural gas, nitrogen, digester gas, biogas, argon, carbon dioxide, and other gases and gas mixes.

The Sage 200/300 Series is a line extension of the Sage Prime. These products provide the same performance as the Prime model with fewer features and less functionality at economical pricing. The 200 Series is available with and without display and with integral electronics. The display provides a reading of the flow rate, total flow, and gas temperature. The 200 Series is for customers outside of the United States and Canada, and the 300 Series is only for the United States and Canada, but only as a blind meter (without display). The table listed here shows the various model combinations.

Integral Model	Display
201	yes
211/311	no

Both the 200 Series and 300 Series provide a 4-20 mA and a pulse signal. Modbus RS485 RTU is optionally available. The 200 and 300 Series use either 24 VDC or 115/230 VAC input power.

Please let us know if we can assist you in any way with your Sage meter. If you have any questions regarding installation, operation, or features, call 866-677-SAGE (7243), or visit SageMetering.com to contact a factory representative in your area. This manual is available to download with other product literature under Doc-Downloads at <https://sagemetering.com/product-literature-downloads/>.

Sincerely,

Bob Steinberg

President



SECTION A:

Getting Started

Unpacking Your Sage Meter

Your Sage flow meter is a sensitive yet rugged, precision-built electronic instrument. Upon delivery, take care when opening the shipping container and removing your meter. Inspect the meter for any damage that may have occurred during transit. If there is any damage, please contact the carrier immediately to place a claim for damaged goods.

Check the contents of the container against the packing list for any discrepancies. If there are any questions about the configuration of the equipment, including calibration ranges, or mounting hardware, contact Sage Metering for assistance. Please save the shipping container and packaging materials (including PVC tube probe protector on Sage insertion flow meters) if the unit needs to be returned for any reason.

Maintenance

Sage thermal mass flow meters require little or no maintenance. While the sensing element is somewhat resistant to dirt and particulate

buildup, it may become necessary to clean it from time to time if mounted in exceptionally unclean environments. **Note: Always remove the power before any cleaning or maintenance.** A detergent or appropriate non-corrosive solvent for removing the buildup may be required. A soft brush can gently clean the sensing element's surface, using caution to avoid damaging the sensor elements (the RTDs). If any disassembly is necessary, contact Sage Metering for instructions. **When the meter requires cleaning, repair, or recalibration, returning the equipment to the factory has historically proven to be the most cost-effective and reliable choice.**

Calibration

Each flow meter is individually calibrated for the specified gas and flow rate on the application sheet submitted with each order. The unit is factory configured for the process and installation parameters. A Certificate of Conformance is included with each unit.



CAUTION—The cable glands shipped with the unit are for shipping purposes only. Remove shipping cable glands before installing.



CAUTION—If installing in a Class I hazardous location, the installation must comply with appropriate electrical codes.



CAUTION—The installer must supply proper ground and bond wire for the transmitter and the sensor per appropriate electrical codes.

Installation and Mounting

EN60079-14 Standard for Electrical Installations

Check the Certificate of Conformance included with your Sage thermal mass flow meter for system pressure, temperature, gas composition, power input, and signal output.

Insert the flow meter in a location providing maximum straight run. Refer to Flow Conditioning and Straight Run on [page 11](#). Note that obstructions such as valves, blowers, expanders, PVC, and HDPE pipes require additional straight run (contact the factory for assistance).

Check the display orientation—The standard calibration flow direction is left to right when facing the flow meter. Gas flow direction is marked by an arrow on inline flow meters, while **upstream** is marked on insertion probes. If the enclosure is facing *incorrectly*, rotate the enclosure 180°, but **never** rotate the probe, or errors may occur. The **upstream** mark still needs to be facing upstream.¹

Hook up the system by referring to the wiring diagram provided with your Sage flow meter (see the inside of the rear compartment cover for terminal designation). Verify that the wiring for the power and signal connections is correct.

Inspect that all the plumbing and electrical hook-ups comply with OSHA, NFPA, and all other safety requirements.

Locating Proper Wiring Diagram

See [pages 18–20](#) for electrical wiring of the Sage 200/300. There is an illustration in the electronics cover which shows wiring connections.

See [page 18](#) for a wiring diagram of the DC or AC input power. [Pages 19 and 20](#) give wiring connections for the output signals.

Note: Do not open the display side of the enclosure.

¹ The integral-style Sage 200/300 Series insertion meter has the display oriented as shown in Figure 6 on page 14. If the enclosure needs to be rotated, this can be performed in the field (see below). If, however, the display needs to be rotated, **do not** attempt this in the field and return the meter to Sage for modification. Complete an RMA form before returning the meter (see page 41).

The procedure for rotating the *enclosure* is:

1. Clamp the enclosure of the 200/300 Series in a vise with the probe pointing up at the ceiling.
2. Take a 7/8" wrench and turn the probe to the proper orientation.
3. Lock the probe into its new position with a set screw (not provided).

Insertion Flow Meter Application

Flow Profile and Installation Considerations

Insertion flow meters are generally easier to install than inline flow meters; however, to perform correctly, they require proper installation and a well-developed flow profile. Please refer to the following sections, [Probe Insertion Guideline](#) (page 14) and [Installation Depth Chart](#) (page 15).

Sage Valve Assembly Operation

Valve assemblies (SVA05LP, SVA05) are optional mounting hardware for insertion-style flow meters (see Figure 1). The hardware allows the removal of insertion-style meters for service, cleaning, recalibration, and relocation without the need to shut down the process. The probe insertion depth is adjustable to permit the sensor to be at the center, optimizing measurement accuracy ([Figure 6](#), [Figure 7](#), and [Figure 8](#) on pages 14 & 15). The ball valve seals off leaks of the process gas at the insertion point after removing the probe assembly. The assembly includes a valve, threadolet, compression fitting with Teflon ferrule, a cable restraint, and two collar clamps (except for SVA05LP).

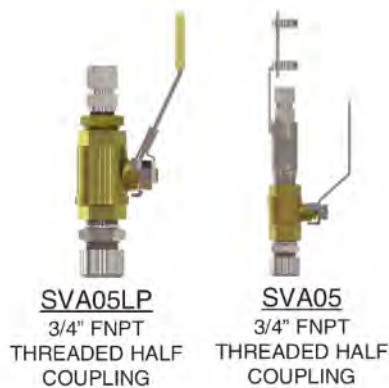

Figure 1: Optional Valve Assemblies

A threaded half coupling, as subsequently defined, must be fitted to the pipe/duct to which the insertion probe inserts. **Avoid T-fittings since they disturb the flow profile and reduce the measurement area.** Direct threading together (or with necessary bushings) of the retractor assembly may be required. In other cases, the threadolet must be welded in place, and a clearance hole must be drilled through the pipe/duct to accept the probe assembly. **If the pipe/duct is under pressure during installation, a hot tap drill (not available through Sage Metering) may be required.**

Flow Conditioning and Straight Run

To absolutely assure that the flow profile is well developed at the measurement point, either use flow conditioners (standard in Sage inline flow meters, 1/2" and larger, and optional assemblies for insertion flow meters) or consider an additional straight run. Figure 2 shows the amount of straight run needed to assure there are no flow disturbances at the measurement point.

IMPORTANCE OF FLOW CONDITIONING Recommended Pipe Diameters Upstream		
DISTURBANCE	Without Flow Conditioning	With Flow Conditioning ¹
	Minimum Industry Recommendation	Sage Recommendation
One 90° Elbow	25	3
Two 90° Elbows in the Same Plane	36	5
Two 90° Elbows in Different Planes	62	9
4:1 Area Reduction	18	3
4:1 Area Expansion	84	10
Multiple Disturbance	TBD	TBD

¹ This column applies to in-line flow meters, which come standard with built-in flow conditioners, as well as insertion meters, when installed with upstream Captive Flow Conditioners.

Figure 2: Straight Run Chart

Compression Fitting Operation

A bored-through tube fitting, adequately sized to accommodate an insertion probe's particular OD, can be optionally purchased from Sage or provided by the user (see page 30). Before installation, drill a clearance hole to accommodate the insertion probe assembly in the pipe/duct. A fitting (1/2" FNPT) is then welded in place or threaded into the half-threadolet, which has been welded to the pipe/duct. The probe insertion depth is adjustable to permit the sensor to be located at the center, to optimize measurement accuracy. (Refer to [Probe Insertion Guideline Drawing and Charts](#), pages 14–15.)



Figure 3 - Insert the probe shaft tubing into the compression fitting to the position indicated in the probe insertion guidelines.

Installation Instructions

1. Insert tubing into the tube fitting.
2. Ensure the tubing is adequately positioned per the [Probe Insertion Guideline Drawing and Charts](#) on pages 14–15.
3. Due to the variations of tubing diameters, a common starting point is desirable. Therefore, tighten the nut until the tubing does not turn by hand or move axially in the fitting.
4. Scribe the nut at the six o'clock position.
5. While holding the fitting's body steady, tighten the nut 1 1/4 turns to the nine o'clock position.

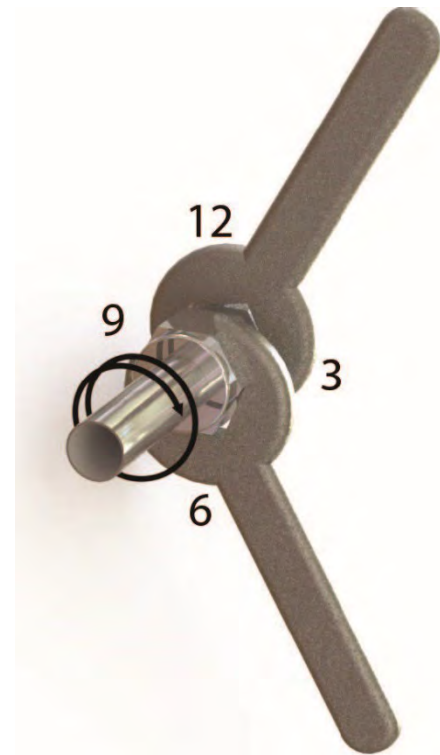

Figure 4 - While holding the fitting's body steady, tighten the nut one and one-quarter turns to the 9 o'clock position.

Captive Flow Conditioners

Captive Flow Conditioners are used with insertion-style flow meters.

IMPORTANT—The location of the probe must be one pipe ID diameter (such as 4" in a 4" pipe; 6" in a 6" pipe) downstream of the flow conditioner, or errors occur. The Captive Flow Conditioners are always designed to be separated by one pipe diameter. See Figure 5.

IMPORTANT—When using Captive Flow Conditioners, it is essential to calibrate the accompanying Sage Flow Meter with the flow conditioner. **Do not** order a flow conditioner separate from the flow meter unless the flow meter part number is “-FC.”

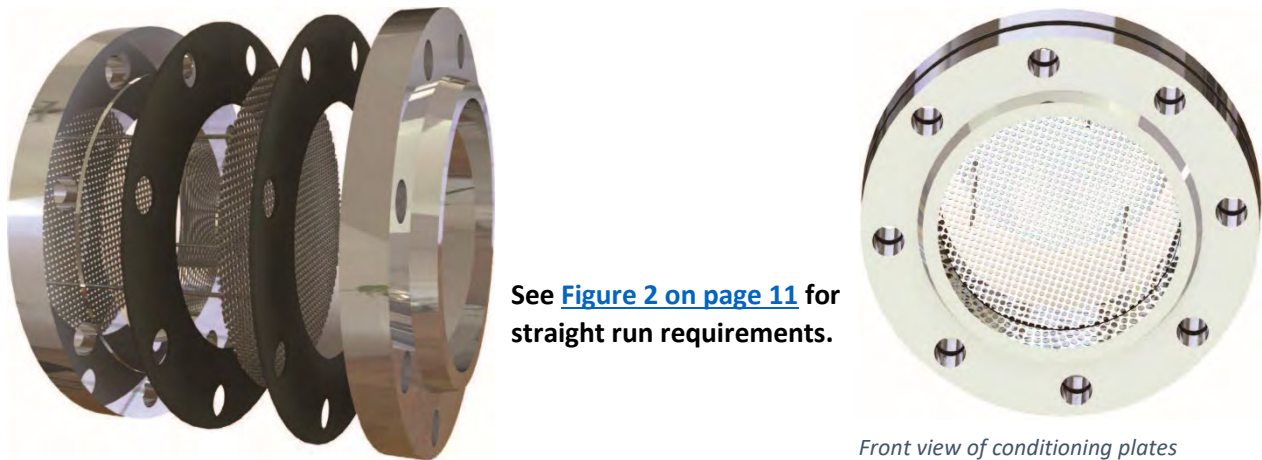
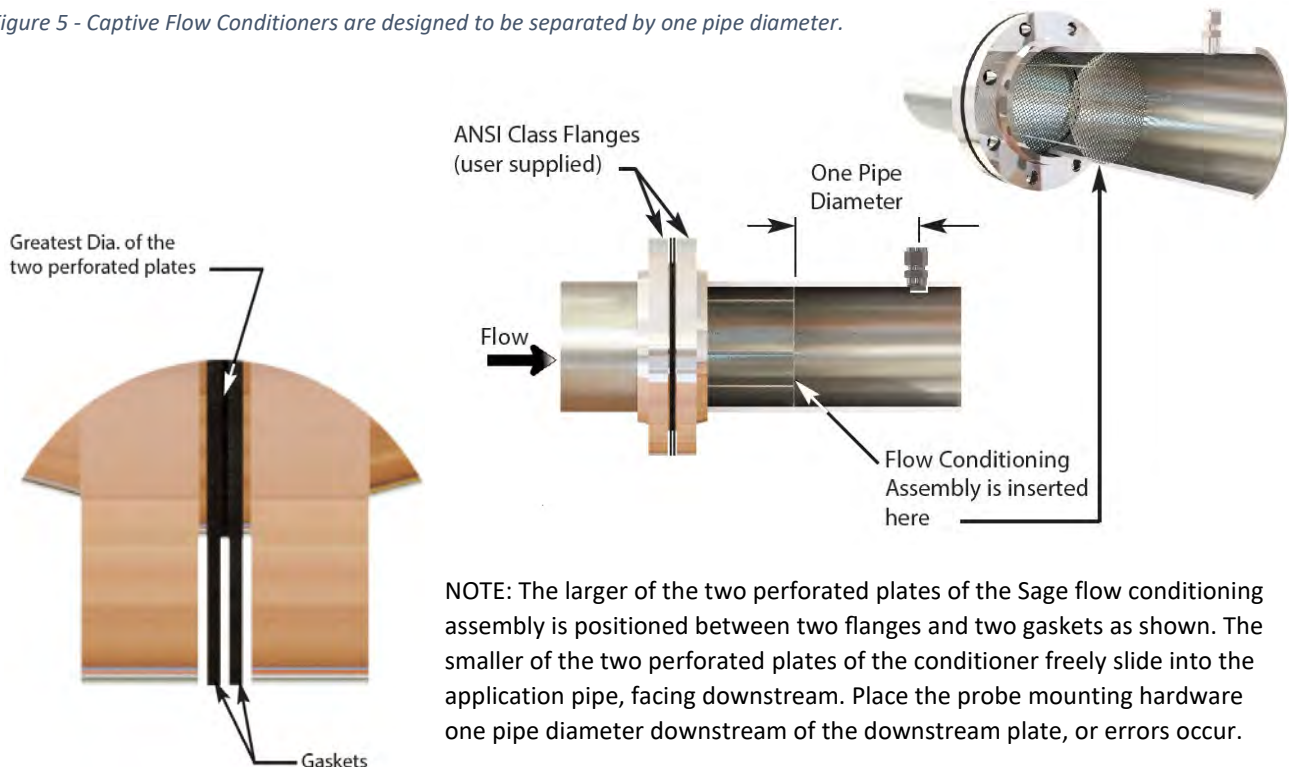

Figure 5 - Captive Flow Conditioners are designed to be separated by one pipe diameter.



NOTE: The larger of the two perforated plates of the Sage flow conditioning assembly is positioned between two flanges and two gaskets as shown. The smaller of the two perforated plates of the conditioner freely slide into the application pipe, facing downstream. Place the probe mounting hardware one pipe diameter downstream of the downstream plate, or errors occur.

Probe Insertion Guideline

Choose the longest straight-run section of pipe available to allow a uniform, well-developed flow profile. See [Figure 2](#) on page 11 for recommended upstream pipe diameters. Note that obstructions such as valves, blowers, expanders, PVC, and HDPE pipes require additional straight run (contact the factory for assistance). Avoid, if possible, installations immediately downstream of bends, fans, nozzles, heaters, and especially valves, or anything else installed in the line that may cause non-uniform flow profiles and swirls. Otherwise, signal output errors could result unless a significantly more straight run is provided, or flow conditioners are installed (contact Sage for assistance if needed). Refer to [page 13](#) for the benefits of incorporating flow conditioners.

Insertion styles are available with a standard 1/2" OD probe support assembly. Standard probe lengths are 6", 12", 15", 18", 24", and 30". A common method of mounting the probe assembly through a pipe wall or duct (if ambient air) is using a compression fitting (STCF05). A Sage valve assembly (SVA05) is useful and highly recommended for pressurized applica-

tions or other gases, and a natural gas flange mounting is optionally available.

Sage insertion-style flow meters can be assembled and calibrated for use in virtually any size pipe or duct (as small as 1"). Sage insertion flow meters include a probe assembly that supports the sensing element (a self-heated flow sensor and a temperature/reference sensor); a sensor drive circuit; a microprocessor meter board and transmitter enclosure. The probe assembly must be inserted into the correct position in the process gas flow conduit to allow the gas to flow through the sensor "window" across the sensor element. Position the "sensing point" or active part of the sensor (0.5" from the end of the probe) per [Figure 6](#) and the [Installation Depth Chart](#) on page 15.

Installation Depth

1. [Figure 6](#) shows the Paramount Model 401 insertion meter.
2. The probe should be inserted per the [Installation Depth Chart](#) (See [Figures 7 and 8](#) on page 15) so that the sensors are in the [center of the pipe](#).

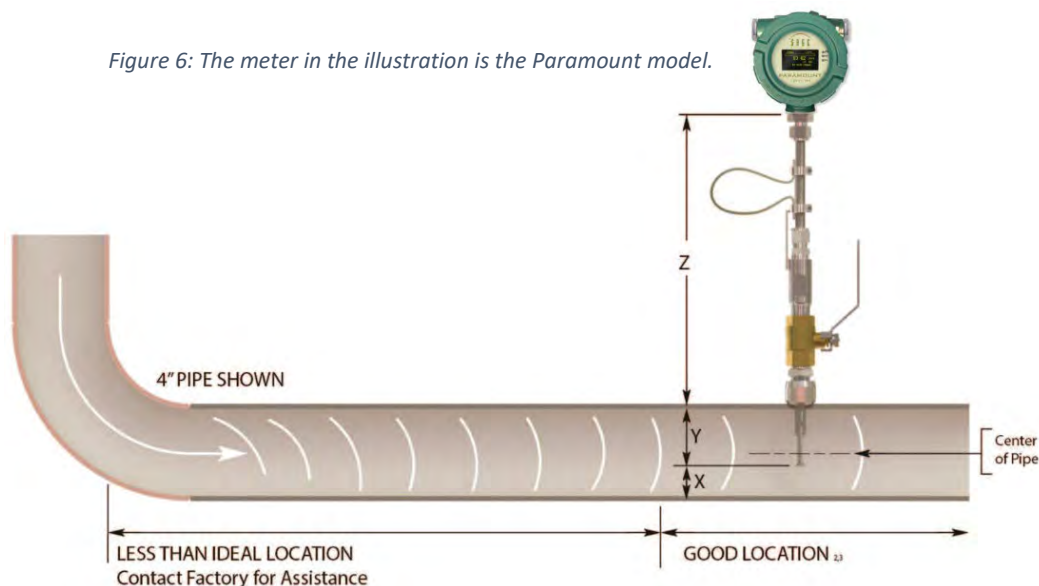

Installation Depth Chart

Methods for Probe Insertion to Pipe Center

Method 1

Using the chart (Figure 8), select pipe size (column 1) and determine X. Insert probe until the end touches the bottom of the pipe (ID), mark the probe as it exits the top of the fitting. Lift probe distance "X" and tighten the compression fitting.

Method 2

Using the chart below, select pipe size (column 1) and insert probe distance Y.

Please Note:

1. The 1" pipe size needs to have the probe "Bottomed Out" (option "BOT").
2. For other pipe, such as Schedule 10, contact Sage; however, the Y dimension is the same for any schedule of pipe.

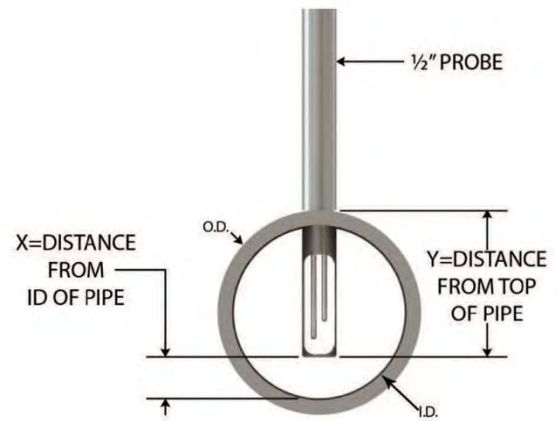

Figure 7: Cross section of a sensor in a pipe

Figure 8 - 1/2" Probe Diameter Installation Chart

PIPE SIZE	OD	ID	X	Y	PIPE AREA
1" ¹	C O N S U L T F A C T O R Y				
1.5"	1.900	1.610	.20"	1.56"	0.0141
2"	2.375	2.067	.40"	1.82"	0.0233
2.5"	2.875	2.469	.60"	2.07"	0.0332
3"	3.500	3.068	.90"	2.38"	0.0513
4"	4.500	4.026	1.40"	2.86"	0.0884
6"	6.625	6.065	2.40"	3.95"	0.2006
8"	8.625	7.981	3.40"	4.90"	0.3474
10"	10.750	10.020	4.40"	6.00"	0.5476
12"	12.750	11.938	5.50"	7.00"	0.7773
14"	14.000	13.124	6.00"	7.50"	0.9394
16"	16.000	15.000	7.00"	8.60"	1.2272
18"	18.000	16.876	8.00"	9.60"	1.5533
24"	24.000	22.625	10.75"	12.60"	2.7919

PIPE SIZE	OD	ID	X	Y	PIPE AREA
1" ¹	C O N S U L T F A C T O R Y				
1.5"	1.900	1.500	.15"	1.56"	0.0123
2"	2.375	1.939	.35"	1.82"	0.0205
2.5"	2.875	2.323	.55"	2.07"	0.0294
3"	3.500	2.900	.80"	2.38"	0.0459
4"	4.500	3.826	1.30"	2.86"	0.0798
6"	6.625	5.761	2.25"	3.95"	0.1810
8"	8.625	7.625	3.25"	4.90"	0.3171
10"	10.750	9.750	4.25"	6.00"	0.5185
12"	12.750	11.374	5.13"	7.00"	0.7056
14"	14.000	12.500	5.70"	7.50"	0.8522
16"	16.000	14.312	6.60"	8.60"	1.1172
18"	18.000	16.124	7.50"	9.60"	1.4180
24"	24.000	21.562	10.25"	12.60"	2.5357

Large Duct or Stack Applications

Here is a configuration for utilizing four Sage insertion mass flow meters for large round pipes or ducts larger than 36" to minimize the effects of varying flow profiles. (Contact the Sage Factory to assist with applications of this nature.)

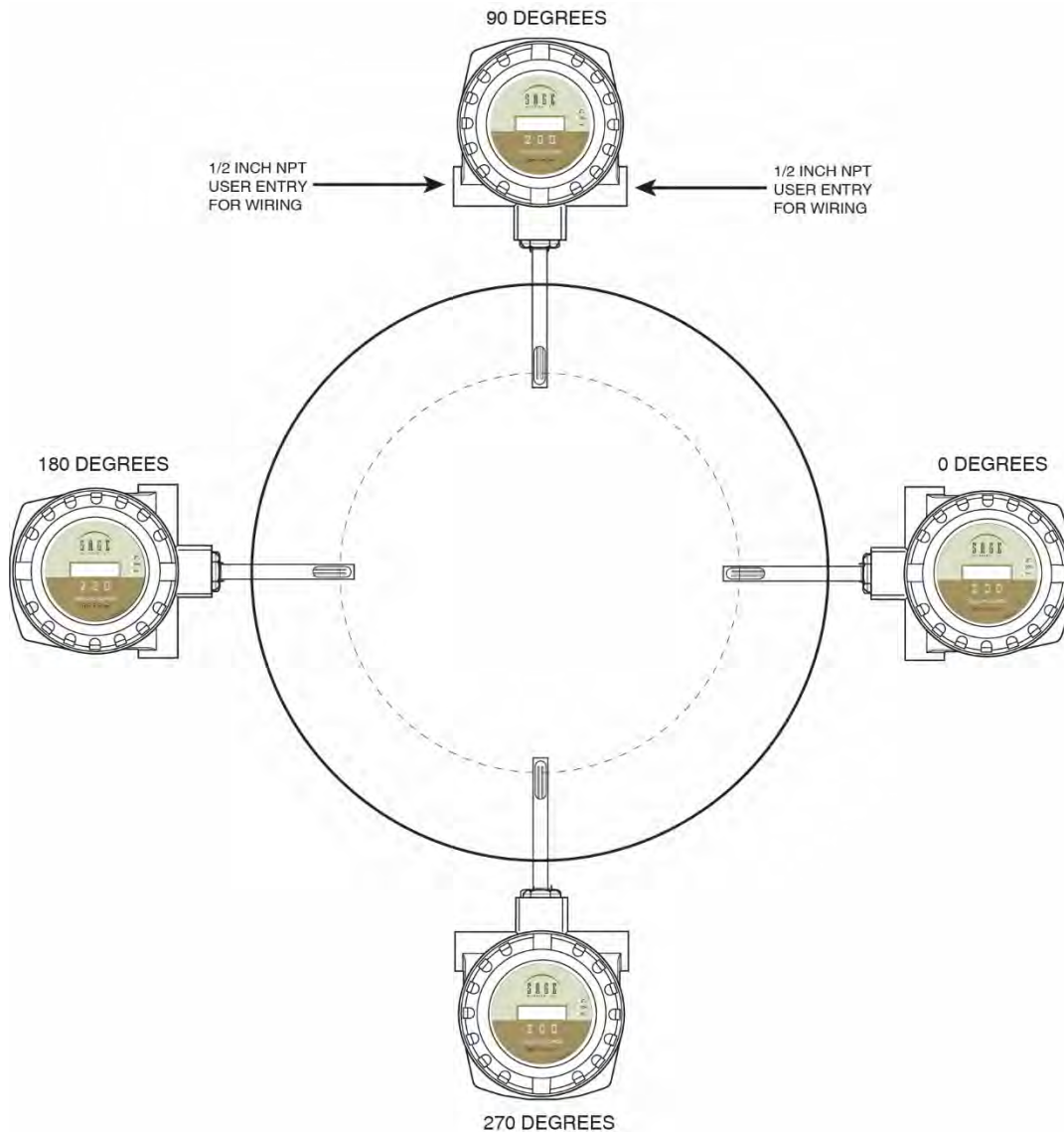

Figure 9: Using Sage flow meters in a large duct or stack

The outputs of the four meters are averaged by the customer's PLC or another method to improve overall accuracy in measuring the flow rate. (For medium-sized round pipes [18" to 36"], two meters, on the opposite side of the same diameter, may be sufficient [insert parallel to an upstream 90-degree bend for optimal benefit.]) Note, in this configuration, each sensor needs to be averaged.

Inline Flow Meter Application

Inline mounting styles are available in sizes 1/4" through 4" pipes. Threaded male NPT ends are standard up to 2 1/2" with ANSI 150 lb. flanged ends recommended for 3" and 4" models. Contact Sage Metering if optional end mounting styles are required. Pipe sizes over 4" require the insertion-style mass flow meter.

The inline-style flow meter assembly flow section is typically specified to match the user's flow conduit and plumbed directly in the flow line by threading, flanging, or welding. **Do not use reducers.** The meter includes the sensing element (a self-heated flow sensor and a tem-

perature/reference sensor) mounted directly in the specified flow section for exposure to the process gas; a sensor drive circuit; microprocessor meter board, and transmitter enclosure.

All inline flow meters, 1/2" and up, have built-in flow conditioners. See [Figure 2 on page 11](#) for upstream straight run requirements. Note that the 1/4" and 3/8" do not have flow conditioners and require more straight run.

Below are flow conditioning screens for inline flow bodies 1/2" and up. [Flow conditioning](#) is available for insertion meter applications (page 13).

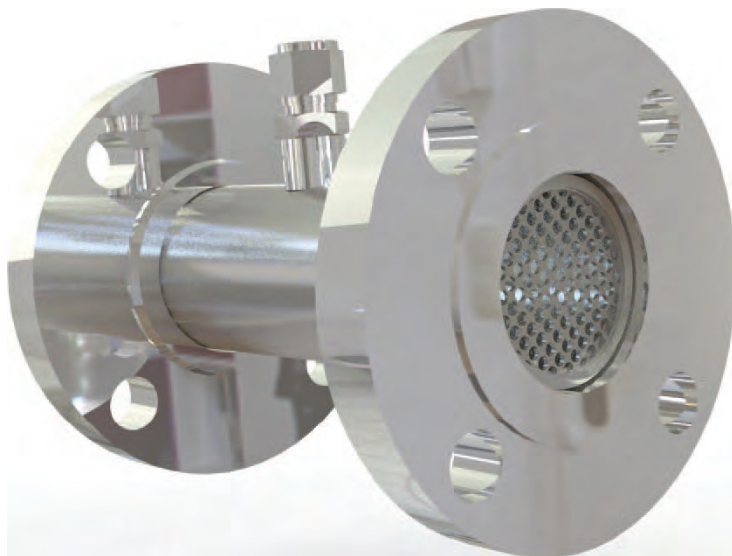

Figures 11 – Above image shows screens with NPT fitting

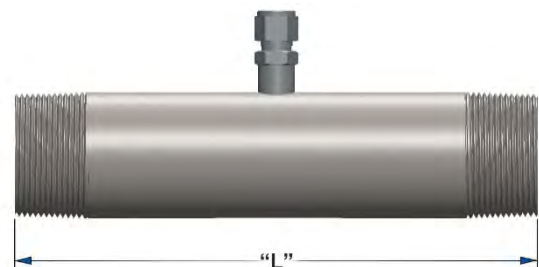
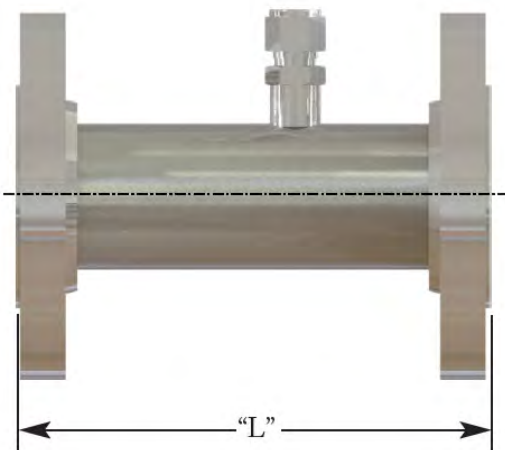

Figure 10 – The length of the flanged-flow body is the same as the NPT-flow body.

Electrical Wiring

All wiring connections are made in the terminal block compartment of the enclosure. An illustration of the wiring connections is found on

the inside of the rear cover. All electrical wiring must meet local code.

Figure 12: Electrical wiring

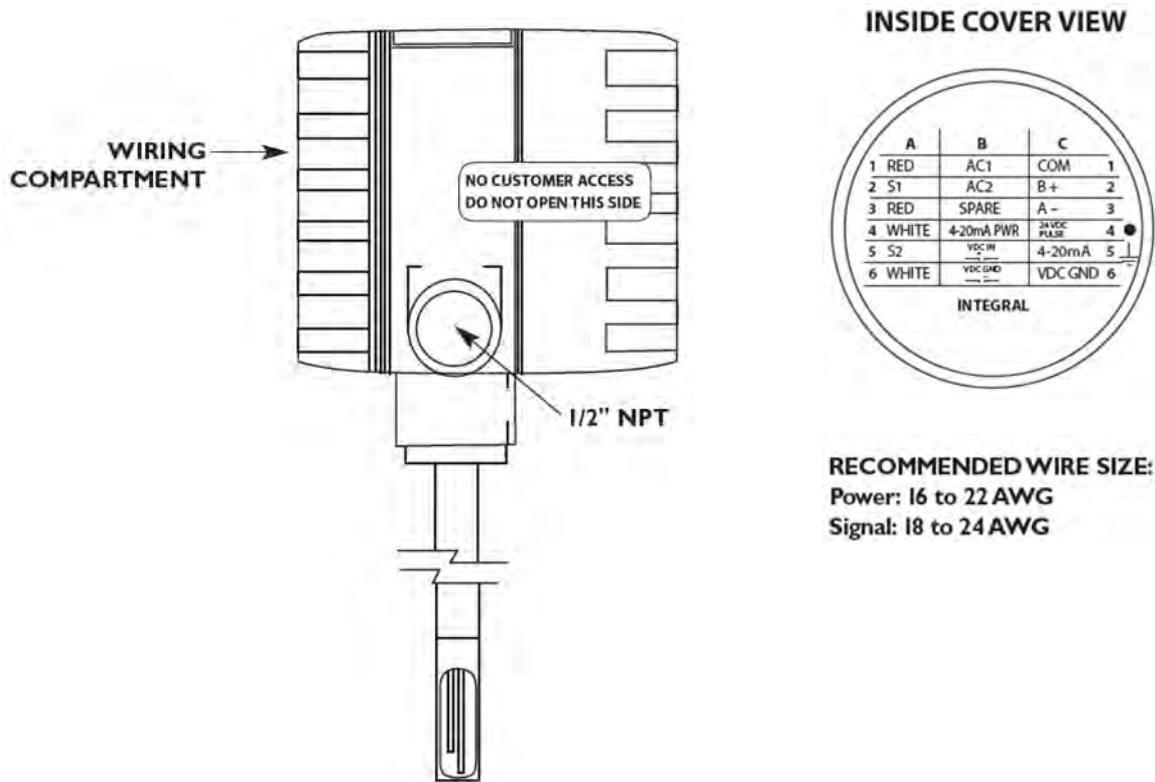

Input Power

The Sage 200/300 Series requires supplemental power in 24 VDC or 115/230 VAC. Power requirements at 24 VDC are 2.4 watts. The AC and DC ground connections are made at the green

grounding screw located adjacent to the terminals. Hazardous area approval is only available on 24 VDC units.

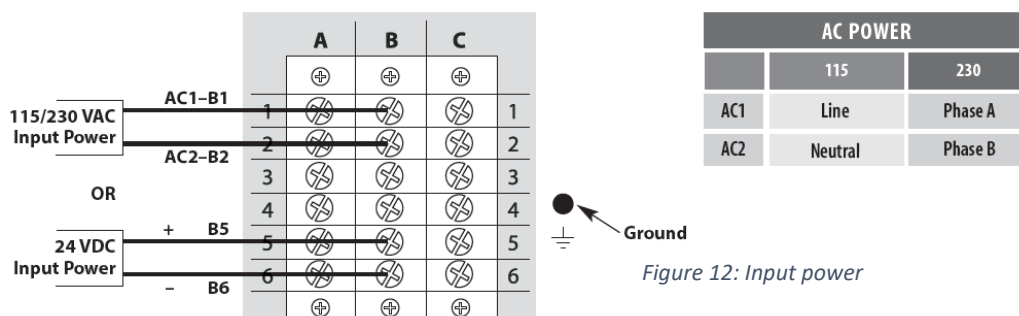

Figure 12: Input power

Output Wiring

Both a 4-20 mA and a pulse output are available. These outputs can be either externally or internally powered. The pulse and 4-20 mA outputs share the same power, so both are internally powered or externally powered.

4-20 mA and Pulse Output Using Separate External Power Supplies

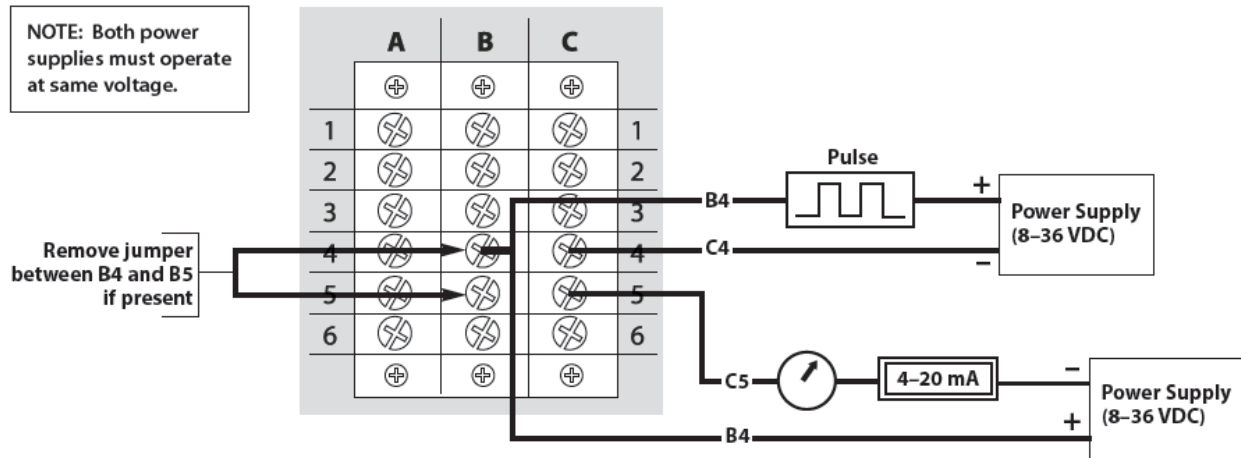
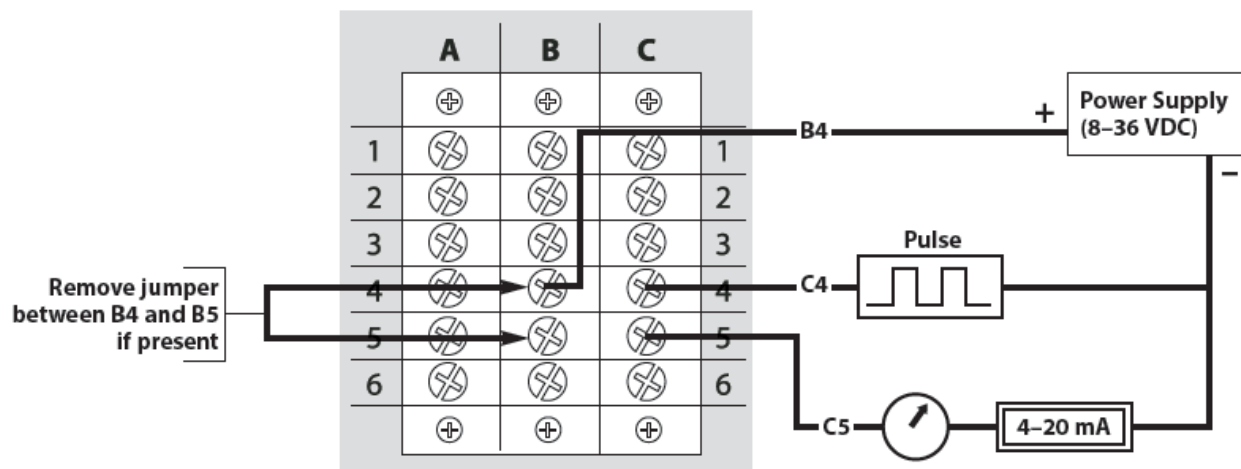

Figure 13: Output wiring with separate power supplies

4-20 mA and Pulse Output Using External Power Supply

Figure 14: Using one external power supply



Pulse Output

The pulse output is 0–10 Hz. The default pulse width is 250 ms. Externally powered voltage can range between 8 and 36 VDC with load not exceeding 100 mA. The internally powered voltage is 24 VDC +/- 10%.

Figure 15: Pulse output

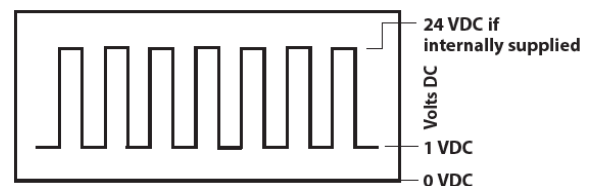

Internally Powered 4–20 mA and Pulse

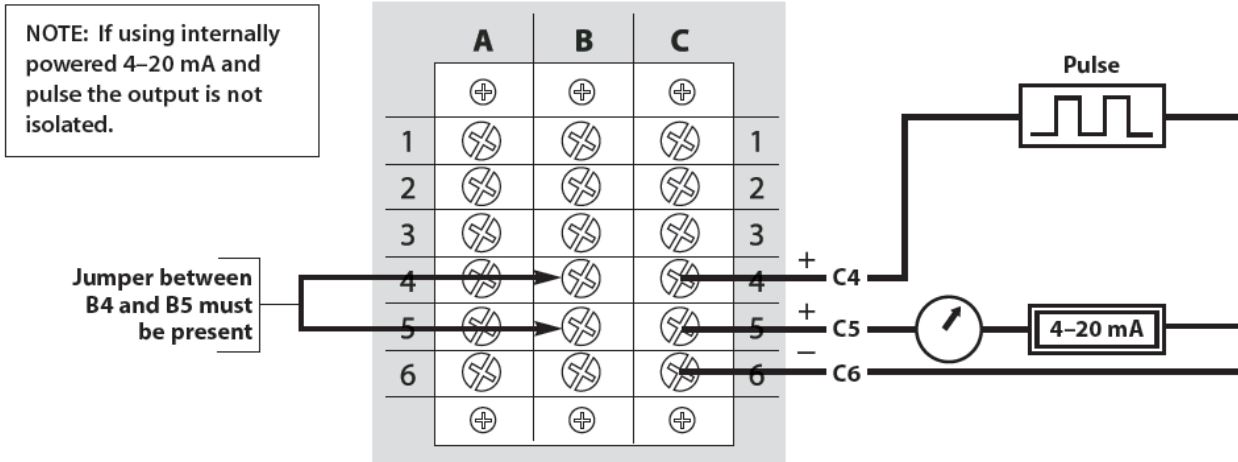
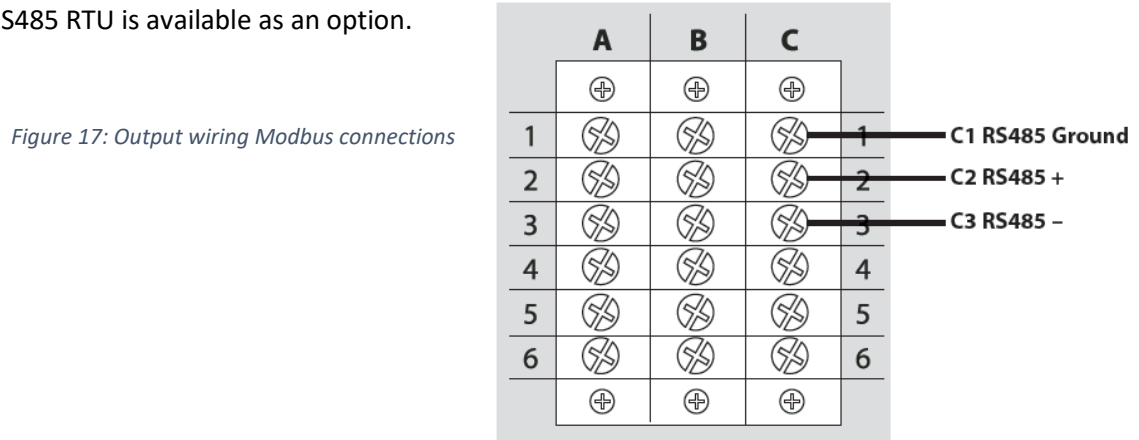

Figure 16: Output wiring— Internally Powered 4–20 mA and pulse

Modbus Connections

Modbus RS485 RTU is available as an option.



Integral Electronics Sensor Connections

Wiring between the sensor and the electronics is completed and tested by Sage. The user rarely accesses these connections.

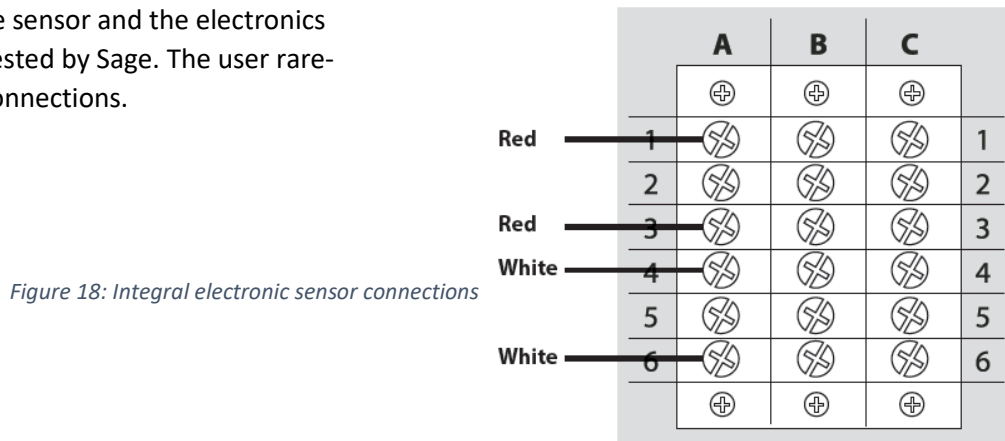

SECTION B:

Styles and Features

Principle of Operation of the Thermal Mass Flow Meter

Sage thermal mass flow meters have two sensors constructed of reference-grade platinum windings (RTDs). The two RTDs are clad in a protective 316SS or Hastelloy C sheath and driven by a proprietary sensor drive circuit. One sensor is self-heated (flow sensor), and the other sensor (temperature/reference sensor) measures the gas temperature. The pair is referred to as the sensing element and is either installed in a probe as an Insertion style or inserted into a pipe section as an inline-style flow meter.

As gas flows by the flow sensor, the gas molecules carry heat away from the surface, and the sensor cools down as it loses energy. The sensor drive circuit replenishes the lost energy by heating the flow sensor until it is a constant temperature differential above the reference sensor. The electrical power required to maintain a constant temperature differential is directly

proportional to the gas mass flow rate and is linearized to be the output signal of the meter.

This constant temperature differential must be maintained, even if there are wide fluctuations in gas temperature. It is the function of the Sage hybrid-digital proprietary sensor drive circuit to keep the differential, whether or not the gas temperature changes, or however quickly molecules cool off the flow sensor. It is also necessary to properly calibrate the device with the actual gas (or close equivalent with certain gases) in the Sage National Institute of Standards certified (NIST) calibration facility. By accomplishing these two critical objectives, the Sage meters provide an extremely repeatable (0.2% of Full Scale) and accurate output directly proportional to the mass flow rate of the gas being measured.



Figure 19 - One of the sensors is self-heated, and the other sensor measures the gas temperature.

Features and Benefits

SAGE 200/300 Thermal Mass Flow Meter

The Sage 200/300 Series of products provide the same performance levels as the Sage Prime with fewer features and economical pricing. The 24 VDC versions are agency approved¹ for use in Class I, Division 2 hazardous areas. Both 24 VDC and AC versions are CE approved. The Series 200 and 300 are available with 24 VDC or 115/230 VAC input power. The power dissipation is under 2.5 watts (e.g., under 100 mA at 24 VDC). These units have an output of a 4-20 mA signal and a pulse output of total flow. Modbus RTU with RS-485 communication is optionally available. The Modbus can be used for both daisy chain communication and reconfiguration of the parameters.

The Sage 200 and 300 Series are designed for integral electronics. All products can be used with either the ½" insertion probe in pipes 1" and larger or the inline flow body with sizes from ¼" to 4".

The 200 Series is available with a display and window or as a blind version. The display provides the reading of flow rate, total flow, and gas temperature. The 300 Series is only available blind (without a display). All units are calibrated in Sage measurements' NIST traceable calibration facility come pre-configured from Sage with the specified process and installation parameters.

As with the Sage Prime, the 200/300 Series use a two-compartment compact housing with a separate wiring section containing large, easy-to-access terminals to simplify field wiring.

The 300 Series is used for domestic use, while the 200 Series addresses the international market.

Location Proper Wiring Diagram

See pages 18–20 for [electrical wiring](#). There is an illustration in the electronics cover which shows wiring connections. See page 18 for a wiring diagram of the DC or AC input power. Pages 19 and 20 give wiring connections for the output signals.

Major Benefits of Thermal Mass Meters

- Direct Mass Flow – No need for separate temperature or pressure transmitters
- High Accuracy and Repeatability – Precision measurement and extraordinary repeatability
- Turndown of 100 to 1 and resolution as much as 1000 to 1
- Low-End Sensitivity – Measures as low as 5 SFPM (e.g., 1 SCFM in a 6" pipe)
- Negligible Pressure Drop – does not impede the flow or waste energy
- No Moving Parts – Eliminates costly bearing replacements and prevents undetected accuracy shifts
- Ease of installation and convenient mounting hardware

Specific Benefits of the Sage 200/300

- The compact design of the enclosure is only 4-1/8" dia. by 4-1/4" deep (DC Models)
- The display of the 200 Series shows flow rate, total flow, and process temperature
- A proprietary digital sensor drive circuit provides enhanced signal stability and unaffected by process temperature & pressure changes
- Modbus compliant RS485 RTU communications (optional)
- Isolated 4-20 mA output and pulsed output of the totalized flow
- Rugged, user-friendly packaging with easy terminal access
- Low power dissipation, under 2.5 Watts (e.g., under 100 mA at 24 VDC)
- Field reconfigurability via optional SageCom software and Modbus (RS485 to USB converter required)
- Flow conditioning built into inline flow meters (1/2" and up)
- Captive Flow Conditioners for insertion meter applications, if required

¹ Only available on 24 VDC powered meters

Sage 200/300 Styles and Specifications (option 1)

SAGE 200™ THERMAL MASS FLOW METERS

The Sage 200 Series of products are the economical alternative to Sage's flagship product, the Prime™. These products offer the same level of performance as the Prime with fewer features. The units are agency approved for use in Class I, Division 2 hazardous areas (DC powered units) and are CE approved. The 200 series is available with 24 VDC or 115/230 VAC input power. The power dissipation is under 2.5 watts which is the lowest in the industry. These units offer both a 4-20 mA signal and pulsed output of totalized flow. In addition, Modbus RTU with RS-485 communication is optional and provides both daisy chain communication and the ability to reconfigure the operating parameters of the instrument with SageCom™ software.

The Sage 200 meters are available with integral electronics. All meters can be used with either the 1/2" insertion probe in pipes 1" and larger or the in-line flow body with sizes from 1/4" to 4". Various connections are available for inserting the probe into the pipe. *See reverse side for more information.*

The 200 is sold for the International Market and is available with a display and window (Model 201) or as a blind version (Model 211). The display provides the reading of flow rate, total flow and gas temperature.



SAGE 300™ THERMAL MASS FLOW METERS

The Sage 300 meters are sold for the Domestic Market, but only the blind version is available (Model 311). It is otherwise identical to the Model 211. For a displayed flow meter version, refer to the Sage Prime (SIP/SRP Series).



All units come calibrated from the Sage NIST traceable calibration facility and are preconfigured with the specified process and installation parameters for the application. Sage's unique In-Situ calibration verification procedure is available only on the Sage Prime, however.

Both the 200 and 300 use a two compartment compact housing with a separate wiring section containing large, easy to access terminals to simplify installation.

SPECIFICATIONS

Performance:

Accuracy: +/- 1% of reading plus 0.5% of full scale

Repeatability: 0.2% of reading

Low End Sensitivity: 5 SFPM (1 SCFM in 6" pipe)

Response Time: 1 second time constant

Turndown: 100:1

Resolution: 1000:1

Electronics:

Power: 24 +/- 10% VDC or 90 - 265 VAC

Output: 4-20 mA

Pulse: Solid State

Isolated: External powered 4-20 and pulse¹

Modbus: RS 485 RTU optional²

Approvals: Class I, Division 2³, NEMA 4, CE

Ambient Temperature: -40 to 150° F (-40 to 65° C)

Sensor:

Type: Insertion probe (1/2" diameter)

Flow Body with flow conditioning (1/4" to 4")

Materials: 316 stainless steel

Process Temperature Range: -40 to 450° F (-40 to 230° C)

Process Pressure: Max 500 psig

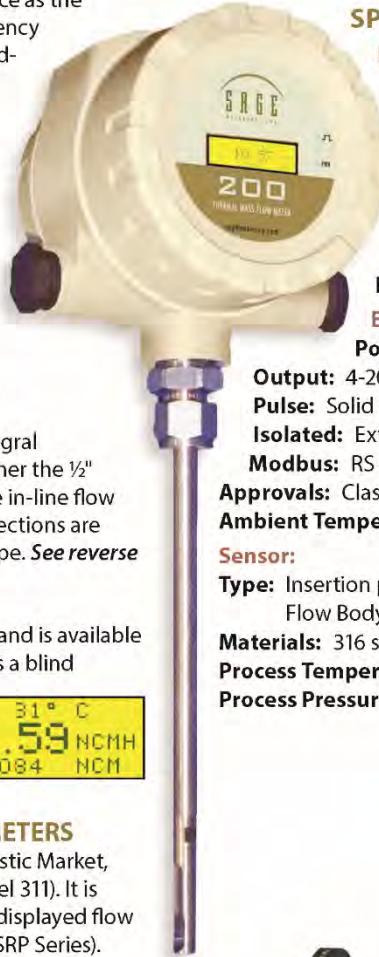

Sage 200 shown with in-line, flanged flow body with sizes from 1/4" to 4".

¹ To externally power for isolated outputs, remove jumper.

² Modbus required for configuration of instrument. SageCom™ software available.

³ DC powered units only.

FLOW SIZING

The Sage thermal mass flow meters can be used for essentially any gas, but the sizing will vary for different gas types. The two most common gases Sage flow meters are used for are air and natural gas. The following charts

provide the maximum flow rates for these gases in various pipe sizes. For flow rate of other gases, consult Sage Metering or visit the *Build a Meter* section at: sagemetering.com/build-a-meter

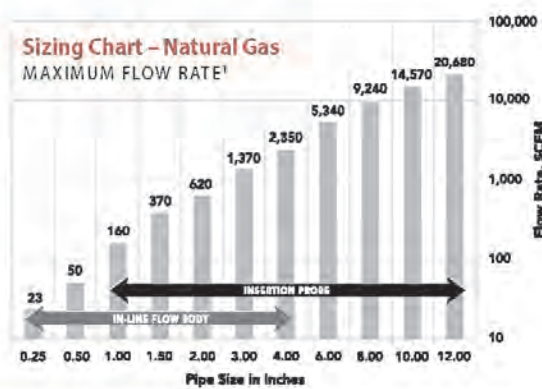
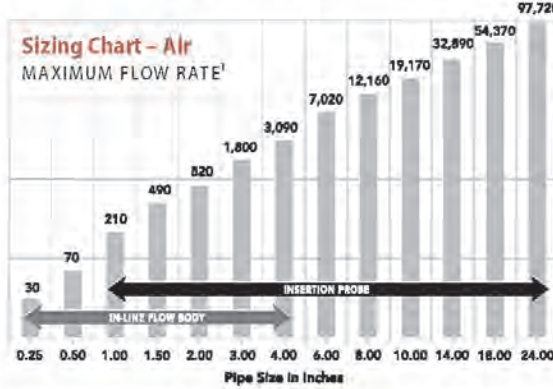

FITTINGS AND PROBE LENGTH

Sage can provide different fittings for inserting the probe into the pipe. The most popular are the simple low-pressure valve and compression fitting (SVA05LP) and the high-pressure valve and fitting with safety cable (SVA05). Refer to the table for recommended probe lengths for each fitting for various pipe sizes.

Probe Length of Insertion Probes

PIPE SIZE	STCF05 Compression Fitting <125 PSIG	SVA05LP Isolation Valve Low Pressure <50 PSIG	SVA05 Isolation Valve High Pressure <250 PSIG
1" - 3.5"	6"	12"	15"
4" - 12"	12"	15"	18"
14" - 24"	15"	18"	24"
30"	18"	24"	30"
36"	24"	30"	36"

FLOW CONDITIONING

When using an insertion probe, the accuracy is dependent on the flow profile in the pipe. The desired flow profile naturally develops with sufficient straight run of the pipe. In cases where there is insufficient straight run, Sage Metering provides flow conditioning elements that insert into the pipe.

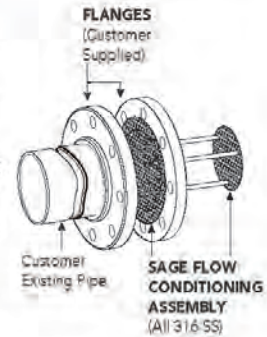

DIMENSIONS

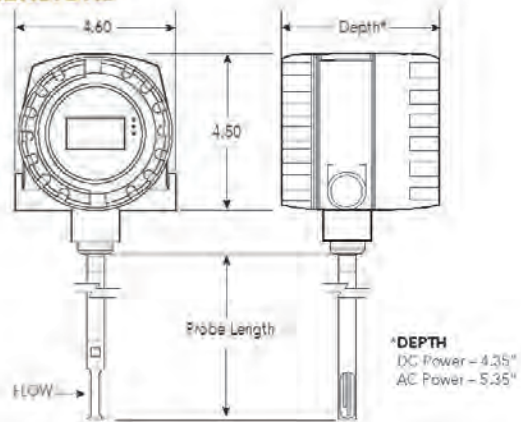

MODEL NUMBER BREAKDOWN

Model	Display	Electronics	Probe Size	Probe Length	Power	Gas Type	Mounting Hardware
2 = 200 Series 3 = 300 Series (Blind Only)	0=Yes 1=No	1=Integral	05=1/2"	See Table	DC24 AC115 AC230	Specify Gas	SVA05 SVA05LP STCF05

Example: 201-05-18-DC24-AIR Example: 311-05-15-DC24-NG

¹ Max Flow Rate accuracy on 1-1/2", 2", 2-1/2", and 3" pipes slightly derated due to extrapolation

Sage Metering, Inc. / 8 Harris Court / Bldg D / Monterey, CA 93940 / 866-677-SAGE (7243) / 831-242-2030 / Fax 831-655-4965 / www.sagemetering.com

v. 200/300-0421 PAGE 2

Sage Display

Available on the 200 Series.

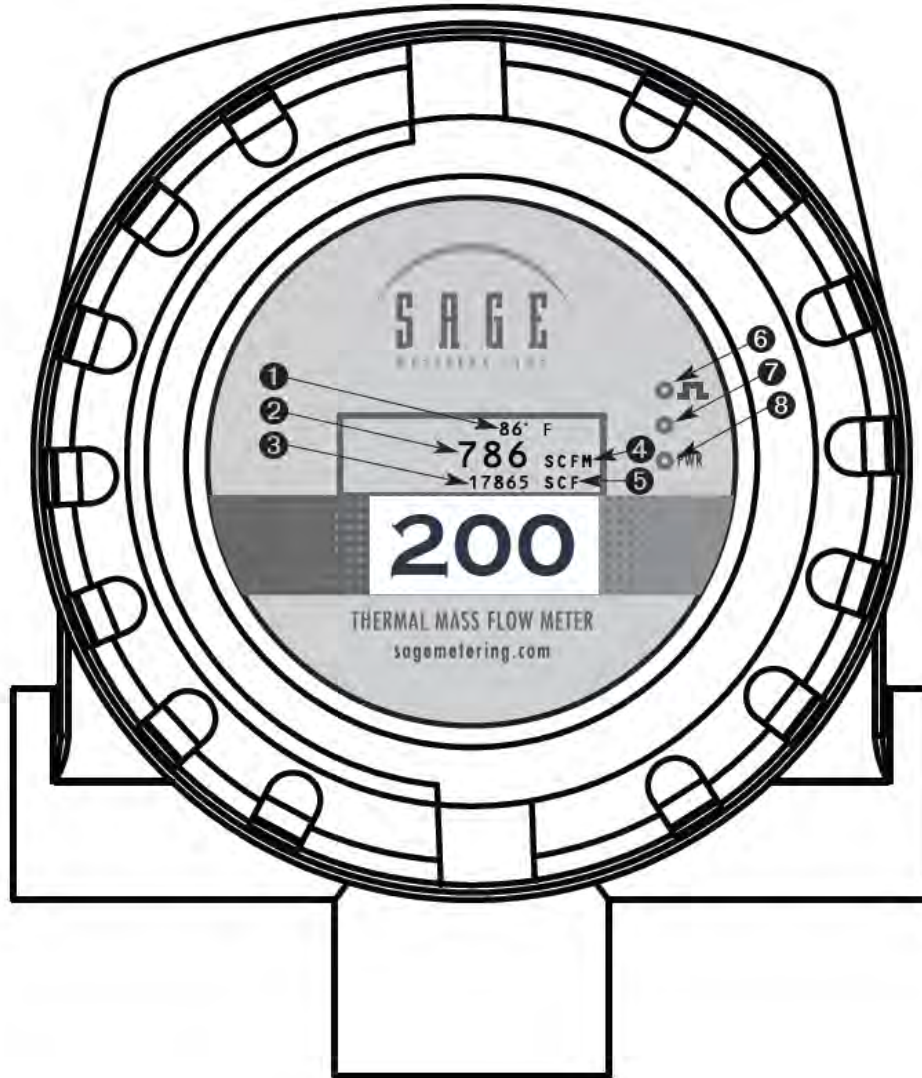

1. Gas temperature
2. Flow rate
3. Totalized flow
4. Engineering units of flow rate
5. Engineering units of totalized flow
6. Flashes with each pulsed output of consumption
7. Indicates original Modbus is being transmitted
8. Indicates optional Modbus is being received

Approvals

Hazardous Location Approvals

All 24 VDC-powered Sage Series 200/300 Meters are Class I, Div 2, Groups B, C, D, T4. AC-powered meters are not Class I Div 2 approved.

Testing under the following safety standards:

- ANSI 12.12.01, Electrical Equipment for Use in Class I and II, Division 2, and Class III Hazardous (Classified) Locations
- CSA C22.2 No. 213-M1987 (R1999), First Edition, Nonincendive Electrical Equipment for Use in Class I, Division 2 Hazardous Locations
- UL/CSA 61010-1, Second Edition, Safety Requirements for Electrical Equipment for Measurement, Control, and Laboratory Use—Part 1: General Requirements

The following is required to comply with the approvals mentioned above:

1. Repair of the product (or replacement of components) is not possible by the user
2. As noted on the label shown above, there are the following markings: Ex symbol, nA symbol IIC, temperature class
3. All DC meters are marked with “X,” which means that these Special Conditions of Use applies:
 - a) The completed meter must be installed with a rigid or flexible metal conduit to satisfy approval conditions.
 - b) The meter is approved for use with the electronics enclosure in ambient temperature from $-40^{\circ}\text{C} < T_a < 65^{\circ}\text{C}$.

4. Sage Metering considers a linear correction suitable for temperatures exceeding the 40°C (104°F); thus, no customer correction is needed.

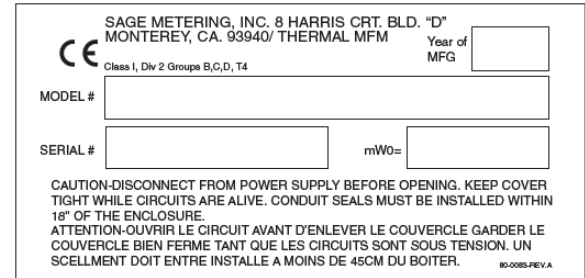

Figure 20

CE Conformance

All AC & DC powered Sage Metering 200/300 Series are CE Compliant for the following CE directives:

- EN61000-6-4 for Electromagnetic compatibility
- EN61000-3-2 for Harmonics
- EN61000-3-3 for Flicker
- EN61000-6-2 for Electromagnetic Compatibility (Immunity for Industrial Environments), which includes EN61000-4-2 for ESD
- EN61000-4-3 for Radiated Immunity
- EN61000-4-4 for EFT/B; EN61000-4-5 for Surge
- EN61000 for Conducted Immunity
- EN61000-4-8 for Magnetic Immunity
- EN61000-4-11 for Voltage Interruptions

SECTION C:

Drawings

200/300 Series Integral Style Mass Flow Meters

Inline Style^{1,3}

150#, 300#, or 600# flanged ends are optionally available. (150# flanges recommended on 3" and 4" flow bodies)

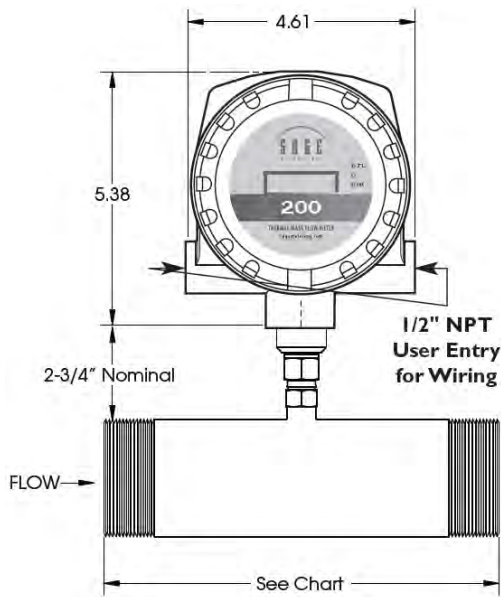

Caution:

Do not rotate the enclosure of inline-style meters relative to the flow tube, or the calibration may be affected since the sensors may become misaligned.

IN-LINE METER DIMENSIONS

Pipe Size x Flow Body Length (B)³

1/4" x 6"

3/8" x 6"

1/2" x 7"

3/4" x 7"

1" x 8"

1-1/4" x 10"

1-1/2" x 12"

2" x 12"

2-1/2" x 12"

3" x 12"

4" x 12"

Depth: DC Enclosure depth is 4.35"
AC Enclosure depth is 5.35"

Insertion Style²

150#, 300#, or 600# flanged mounting is optionally available. Available probe lengths are 6", 12", 15", 18", 24", 30", 36" or 48". Standard probe is 1/2" diameter.

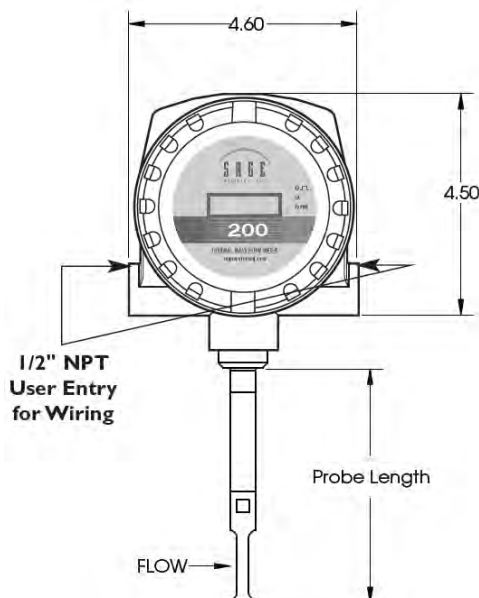

¹ NPT fittings standard

² Flanged mounting available for high-pressure operation

³ Flow conditioning built into flow meter for pipe sizes 1/2" and up. Contact Sage for optional 1/4" tube flow body.

Mounting Hardware³

SVA05 Series Isolation Valve Assembly for Insertion Meters⁴

(For [Low-Pressure SVA05](#), see page 31.)

Used for pressures to 250 psig¹ (shown for use with 1/2" diameter insertion meters). 150# or 300# flanged mounting is optionally available.

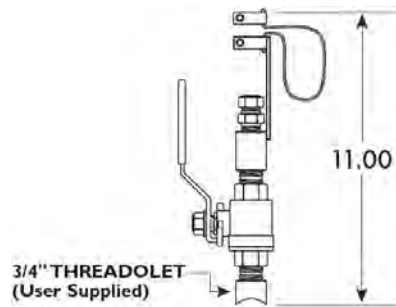

NOTE: The user needs to weld a 3/4" female threadolet (of appropriate radius) to mate with the existing pipe after drilling a 3/4" hole in the pipe. The 3/4" male coupling of the Sage Isolation Valve Assembly threads into the user's 3/4" threadolet.

SVA05 Series Isolation Valve Assembly Detail

Cutaway view of a probe inserted through isolation ball valve assembly

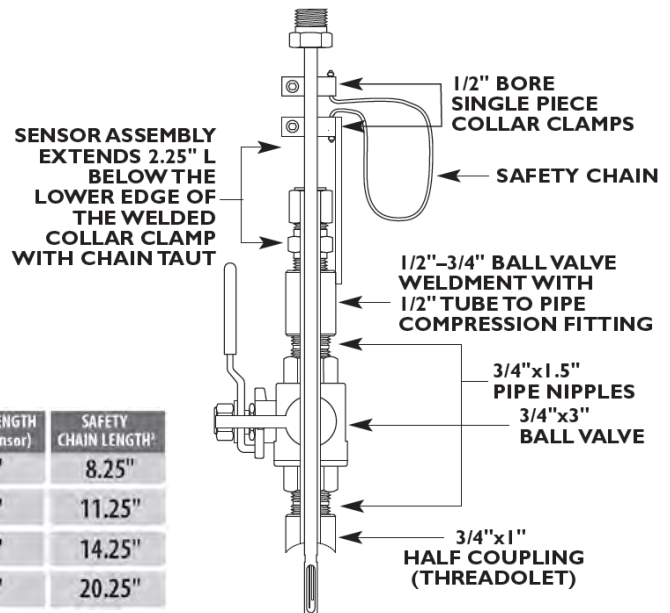

PROBE LENGTH (with sensor)	SAFETY CHAIN LENGTH ²
12"	8.25"
15"	11.25"
18"	14.25"
24"	20.25"

STCF Series Teflon Ferrule Compression Fitting

1/2" tube x 1/2" pipe fitting (shown, not to scale) for low-pressure insertion applications to 125 PSIG (stainless steel ferrule optional for higher pressure applications – up to 225 PSIG).

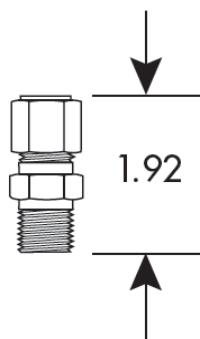

Mounting Plate for Thin-Walled Ducts

(Includes STCF05 Compression Fitting)

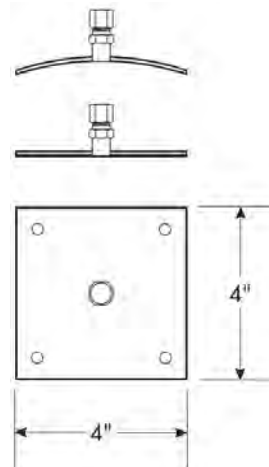

¹At 250 PSIG, the force exerted on a 1/2" diameter probe is 50 lbs.

²Safety chain prevents the probe from accidentally escaping from the assembly during removal from a pressurized pipe.

³Insertion meters can have optional flanged mounting (generally used for high pressure or very hot gases). This adaptation is not shown. Consult the factory for details.

⁴Maximum gas temperature, 200F, unless a high-temperature model

SVA05LP Low-Pressure Isolation Valve Assembly

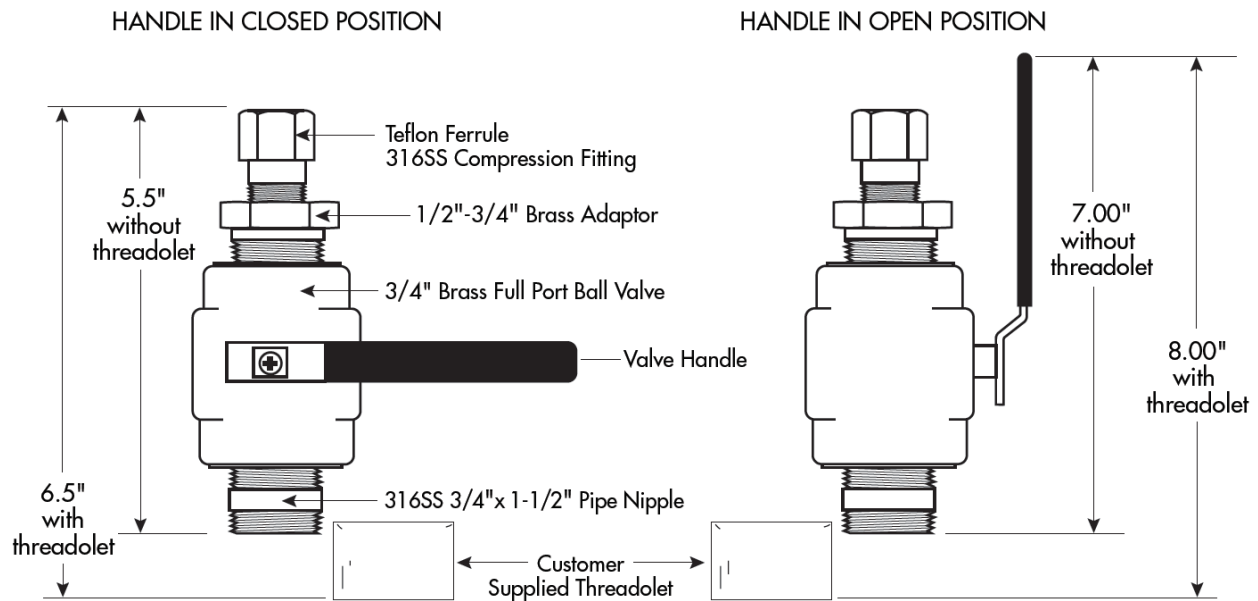

Notes and Cautions

- Suitable for low-pressure air or natural gas applications (maximum 50 PSIG)
- Assumes 1/2" insertion probe inserted to the center of a pipe (see Sage Probe Insertion Guidelines)
- Teflon ferrule permits ease of probe insertion or removal
- Exercise caution when loosening the ferrule nut during insertion and removal of the probe since this model has no safety chain
- The maximum upward force is 20% of pipe pressure (i.e., 10 lbs. with 50 PSIG)
- The assembly ships with a plastic sleeve that protects the 3/4" pipe nipple
- It is the customer's responsibility to weld a female threadolet with the correct diameter to the pipe

Flanged Ends

Inline Meter (Optional)

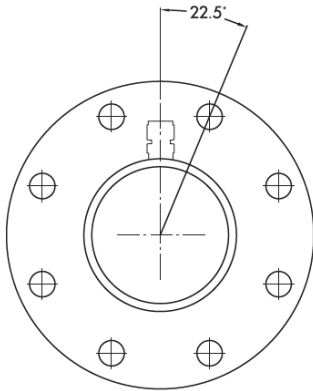

Flanges for 3 1/2" pipe sizes and up,
have 8 bolt holes

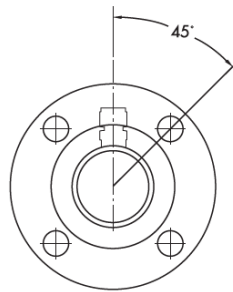

Flanges for 3" pipe sizes and
smaller have 4 bolt holes

Flanged Mounting

for Insertion Meter (Optional)

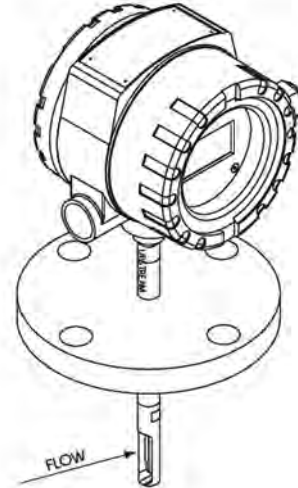

SECTION D:

Diagnostics

Common Diagnostics

Symptom: The display fails, or pixels are extremely dim.

Corrective Action: Contact Sage Metering. Certain types of failures are under long-term warranty. Please note that the 4-20 mA still functions.

Symptom: Display fading or partially fading.

Corrective Action:

- a) Some fading, particularly with those characters lit up most frequently, is normal. The flow meter continues to function correctly, and flow meter accuracy and outputs are not affected.
- b) In extreme cases, contact the factory for display replacement.

Symptom: Erratic readings

Possible Causes: If a large motor or generator, or variable-frequency drive (VFD) is near the enclosure, it may be inducing sufficient analog noise into the circuitry to temporarily corrupt the data.

Suggested Corrective Action:

- a) If a power restart temporarily solves the problem, then the noise source was likely the problem.
- b) Mount the meter in a different location (further from the source) or move the noise source away from the meter.

Symptom: The meter reads zero continuously, or full scale continually, or temperature reading is abnormally low (hundreds of degrees below zero).

Possible Causes/Suggested Corrective Action:

- a) A wire is likely loose. However, in rare cases, a sensor could fail if it exceeds a process temperature of 450°F.
- b) Refer to the integral terminals and check the sensor wires. Remove the appropriate wires first (the red pair for flow, then the white pair for temperature). Measure their resistance. If reading infinity or short, it means that the sensor has failed.

Symptom: Meter railing (pegging) or reading high

Possible Cause/Suggested Corrective Action:

- a) There is insufficient straight run (i.e., flow profile is disturbed, causing errors)
- b) A possible jet effect may exist if the upstream pipe is smaller than the meter flow body or if the valve is too close upstream to the meter.
- c) Are you following the [probe insertion guideline](#) (pages 14-16)?
- d) If the sensor is inserted in reverse (the “Upstream” mark is facing downstream), the meter may over-report (or under-report) as much as 30%.
- e) If the sensor is not aligned correctly, with the “Upstream” mark facing upstream, a rotation greater than ± 5 degrees may cause a change in reading (greater than ± 5 degrees and less than ± 20 degrees causes the meter to over-report; a greater rotation blocks the sensor and causes the meter to under-report).
- f) A downstream valve may be too close to the meter (flow may be reflecting back).
- g) Water droplets may be condensing out of the gas stream (causing the output to

- spike, but if droplets are near-continuous, the output may rail).
- h) The meter may be miswired.
 - i) Water droplets may be condensing on the inside of the pipe wall, rolling down, or hitting the sensor and causing the output to spike. If droplets are near-continuous, the output may rail. Note—*Recommended installation 45° from vertical.*
 - j) Water droplets may condense out of the gas stream and fill the cavity containing the sensing elements (usually due to probes mounted below horizontal in saturated pipes).
 - k) The sensor may be contaminated. Remove the probe, wipe off, or clean with a solvent. Reinsert.
 - l) Are you using a different gas or gas mix than the meter was specified and calibrated?
 - m) The meter may appear to be reading high if the user compares Sage flow meter readings (SCFM) to an uncorrected volumetric device (ACFM). For example, at constant volume, a decrease in gas temperature increases the mass flow (SCFM). That is entirely normal.
- e) If the sensor is not aligned correctly, with the “Upstream” mark facing upstream, a rotation greater than ± 5 degrees may cause a change in reading (greater than ± 5 degrees and less than ± 20 degrees causes the meter to over-report; a greater rotation blocks the sensor and causes the meter to under-report).
 - f) The sensor may be contaminated. Remove the probe, wipe off, or clean with a solvent. Reinsert.
 - g) Are you using a different gas or gas mix than the meter was specified and calibrated?
 - h) The meter may appear to be reading low if the user compares Sage flow meter readings (SCFM) to an uncorrected volumetric device (ACFM). For example, at constant volume, an increase in gas temperature lowers the mass flow (SCFM). That is entirely normal.
 - i) The totalizer does not start counting for 10 seconds after power-up on most models, so any flow data does not accumulate during this time.
 - j) Do you have a sufficient power supply (most products require a minimum of 100 mA)?
 - k) Is there an excessive load on the 4-20 mA? (To check if the problem is due to a 4-20 mA output device, temporarily remove the device, and observe if the display reads as expected.)

Symptom: Reading Low**Possible Causes:**

- a) There is an insufficient straight run (i.e., flow profile is disturbed, causing errors).
- b) A poor flow profile upstream (insufficient upstream straight run)
- c) Are you following the [probe insertion guideline](#) (pages 14-16)?
- d) If the sensor is inserted in reverse (the “Upstream” mark is facing downstream), the meter may over-report (or under-report) as much as 20%.

Symptom: Totalizer can take up to 10 seconds to update its reading when the flow meter is first powered up, or a channel is changed.

Corrective Action: None. This slight delay is entirely normal.

Symptom: The display does not have power

Possible Cause: Mis-wiring

Symptom: 4-20 mA output not tracking the flow rate display

Possible Causes:

- a) In typical operation (self-powered), [B4 and B5 must be jumpered to loop](#). See page 20.
- b) In an externally powered mode, the jumper must be removed. Verify that 9 to 27 Volts DC is [supplied to power the loop externally](#) as per page 19.

SECTION E:

Warranties and Service Work

Limited Warranty

Sage Metering's products are warranted against faulty materials or handiwork for one year from the date of shipment from the factory. Sage's obligation is limited to repair, or at its sole option, replacement of products and components that, upon verification by Sage at our factory in Monterey, California, prove defective. Sage shall not be liable for installation charges, for Buyer's expenses for repairs or replacement, for damages from delay or loss of use, or other indirect or consequential damages of any kind. This warranty is extended only to Sage products properly used and properly installed for the particular application for which intended and quoted, and does not cover water damage due to improper use of cord grips or removal of protective caps. It does not cover Sage products that have been altered without Sage authorization or subjected to unusual physical or electrical stress. Sage makes no other warranty, express or implied, and assumes no liability that goods sold to any purchaser are fit for any particular purpose.

Transportation charges for materials shipped to the factory for warranty repair are to be paid by the shipper. Sage will return items repaired or replaced under warranty, prepaid. NOTE: No items will be returned for warranty repair without prior written authorization from Sage Metering, Inc. Sage does not warranty damage due to corrosion.

General Terms and Conditions

Detailed General Terms and Conditions can be found on the Sage website (www.sagemetering.com) on a link "General Terms" on the Footer of any page on the website.

Cancellation/Return Policy

Cancellation or Return: After issuing a purchase order (by phone, mail, e-mail, or fax) or a credit card order (by phone, mail, e-mail, or fax), there is a cancellation fee for any canceled order. Cancellations must be in writing (by mail, e-mail, or fax):

1. If a credit card order or non-credit card order is canceled within 7 days of issuance of a purchase order or date the order was placed (whichever is earlier), there is a 10% cancellation fee.
2. If a credit card order or non-credit card order is canceled after 7 days but before shipment, there is a 20% cancellation fee. (If an order is canceled due to late delivery, the cancellation fee is waived. Late delivery is defined as shipping a meter 7 days or later than the delivery date acknowledged by Sage Metering when placing the order).
3. If a credit card customer decides to return the equipment after shipment for a credit, the credit is not issued if the equipment is damaged or if the equipment is returned after four months of the shipment. If equipment is not damaged, then equipment can be returned after issuing a Return Meter Authorization (RMA) by Sage. **The returned package must be insured by the customer and must reference proper RMA# on the outside of the package**, or the package may be rejected (i.e., the package is returned unopened). Credit card customers are charged a 30% restocking fee (70% balance is credited back). The customer is responsible for return shipping charges and any damage if improperly packaged.

Continued on next page

4. If a non-credit card customer decides to return the equipment after shipment for a credit, credit is not issued if the equipment is damaged or if the equipment is returned after 1 month of shipment, unless authorized by a representative at Sage Metering, Inc. The Sage representative will issue a Return Material Authorization (RMA) at that time and advise of the restocking fee. **The returned package must be insured by the customer and must reference proper RMA# on the outside of the package**, or the package may be rejected (i.e., package returned unopened). The customer is responsible for return shipping charges and any damage if improperly packaged.

Returning Your Sage Meter

A Return Material Authorization Number (RMA#) must be obtained prior to returning any equipment to Sage Metering for any reason. RMA#s may be obtained by e-mailing: service@sagemetering.com.

See page 41 for RMA information and instructions.

Take special care when packaging your meter for return to the factory. The sensor in particular may easily be damaged if not prevented from shifting around within the package and if the sensor itself is not covered to keep it from contacting other package contents. Any damage resulting from improper packaging is the responsibility of the shipper.

Per the “Right to Know Act” and applicable US Department of Transportation (DOT) regulations, Sage Metering will not accept delivery of equipment that has been contaminated without

written evidence of decontamination and has instituted the following Return/Repair conditions. Strict adherence to these conditions is required. Returned equipment that does not conform to the requirements listed below will not be processed. If Sage Metering finds evidence of contamination, we may, at our option, have the unit returned at your expense. For your reference, the requirements for packaging and labeling hazardous substances are listed in DOT regulations 49 CFR 172, 178, and 179.

The equipment must be completely cleaned and decontaminated prior to shipment to Sage Metering. This decontamination includes the sensor, probe, electronics, and enclosures internally and externally. In addition, all packaging must be clean and free from contamination.

Return Shipping Address:

Attention:

Sage Metering, Inc.
8 Harris Court, Building D6
Monterey, CA 93940

RMA (Return Merchandise Authorization)

If a customer needs to return a meter to Sage, please contact the Service Department via e-mail at service@sagemetering.com.

You **must** include the serial number from the meter, the reason for returning, and the symptoms you're experiencing.

The Sage Service Department will e-mail the customer an RMA# to track the return of the

meter to Sage and instructions on our RMA process.

Or the customer can call our Service Department at 831.242.2030 or toll-free at 866.677.7243 for assistance.

Service Department hours:

Mon–Fri
6:00 am to 3:30 pm PST

SECTION F:

MODBUS

Modbus Register Listing SAGE REV. 1.80–2.07

This section applies to those flow meters which have selected the optional Modbus communication.

Note: MODBUS is an option of the 200/300 Series. Specify “MODBUS” in the overall model part number.

UINT32		IEEE Float		SCALED INT32*		Reg Description
Reg Offset	Reg Offset	Type	Reg Offset	Type		
256		UINT8				format flag
256		UINT8				modbus_unit_id
257		UINT8				output mode sel
257		UINT8				fix_pt selection
257		UINT1				bRun
257		UINT1				bTotal
257		UINT1				bEEProm
257		UINT1				bReset
257		UINT1				bLeadEn
257		UINT1				bDAClo
257		UINT1				bDACHi
	514	FLOAT	770	LONG		CAL_VAL
	516	FLOAT	772	LONG		K-FACTOR
	518	FLOAT	774	LONG		VREF
	520	FLOAT	776	LONG		LOAD-RES
TEMP	522	FLOAT	778	LONG		COEFF A
TEMP	524	FLOAT	780	LONG		COEFF B
TEMP	526	FLOAT	782	LONG		COEFF C
TEMP	528	FLOAT	784	LONG		COEFF D
	530	FLOAT	786	LONG		DISP A
	532	FLOAT	788	LONG		DISP B
	534	FLOAT	790	LONG		DISP C
	536	FLOAT	792	LONG		DISP D
FLOW	538	FLOAT	794	LONG		COEFF A
FLOW	540	FLOAT	796	LONG		COEFF B
FLOW	542	FLOAT	798	LONG		COEFF C
FLOW	544	FLOAT	800	LONG		COEFF D
FLOW	546	FLOAT	802	LONG		COEFF E
FLOW	548	FLOAT	804	LONG		COEFF F

UINT32		IEEE Float		SCALED INT32*		Reg Description
Reg Offset	Reg Offset	Type	Reg Offset	Type		
	550	FLOAT	806			iir filter coeff
	552	FLOAT	808			flow_min
	554	FLOAT	810			flow_max
	556	FLOAT	812			PULSE COUNT
	558	FLOAT	814			temp_max
302		UINT16				dac1_min
304		UINT16				dac1_max
306		UINT32				serial number
308		ASCII				RATE string
310		ASCII				TOTAL string
312		UINT32				current totalizer
314		UINT32				ADC0
316		UINT32				ADC1
318		UINT32				ADC2
320		UINT32				ADC3
	578	FLOAT	834	LONG		current flow
	580	FLOAT	836	LONG		current temp
	582	FLOAT	838	LONG		rtd_mWatts
	584	FLOAT	840	LONG		rtd_res
	586	FLOAT	842	LONG		ref_res_r
	588	FLOAT	844	LONG		ref_res_d
	590	FLOAT	846	LONG		dac_smooth
	592	FLOAT	848	LONG		lead
	594	FLOAT	850	LONG		oheat
	596	FLOAT	852	LONG		bv
	598	FLOAT	854	LONG		fv
	600	FLOAT	856	LONG		tv
	602	FLOAT	858	LONG		lv

*SCALED INT32 register contents form INT32 values by multiplying the IEEE FLOAT x 1000
 ex. FLOAT -> 112.768 = SCALED INT32 -> 112768

Sage Metering Modbus Protocol Rev. 1.80–Rev. 2.07

Sage Meters support communication with other devices via MODBUS® protocol using RTU transmission mode. The Modbus protocol defines a message structure that controllers recognize and use, regardless of the type of networks over which they communicate. It establishes a standard format for the layout and contents of message fields.

Transactions use a master-slave technique, in which only one device (the master) can initiate transactions (called queries). The other devices (the slaves) respond by supplying the requested data to the master and by taking the action requested in the query. Sage Meters operate as slaves to other Modbus devices and default to 19200-8-E-1; however, the following modes may also be software selectable:

9600-8-N-1	(Baud-Bits-Parity-Stop)
9600-8-E-1	
9600-8-O-1	
19200-8-N-1 ¹	
19200-8-E-1	(Default)
19200-8-O-1	

Message Framing

Messages start with a silent interval of at least 3.5 character times followed by 4 fields and followed by another silent interval of at least 3.5 character times. The first field contains the device address. The second field contains the function code. The third field contains the data and byte counts.

¹ Parity on the Wireless Devices manufactured by Obvius is “None” rather than “Even.” The Sage default is 19200-8-E-1. Change to 19200-8-N-1 for the Obvius Modhoppers and related wireless devices.

The fourth field contains the CRC value.

Address Field

The address field contains one byte. Sage Meters transmit response packets to addresses that are between 1 to 240 decimal (inclusive). Modbus packet writes may be sent to broadcast address 00; however, the instrument does not reply with a response packet.

Function Code Field

The function code field contains one byte. See the section titled Function Codes.

Data Field

The data field contains four or more bytes. The meter uses this information to take action defined by the function code or to read or write data to one or many registers.

CRC Field

The CRC-16 (cyclical redundancy check) field is two bytes, containing a 16-bit binary value. The CRC value is calculated by the transmitting device, which appends the CRC to the message. The receiving device recalculates a CRC during receipt of the message and compares the calculated value to the actual value it received in the CRC field. If the two values are not equal, the message is discarded.

Function Codes

03 (0X03) READ HOLDING REGISTERS

Identical operation as code 04 READ INPUT REGISTERS described below, except READ only.

04 (0X04) READ INPUT REGISTERS

Reads the binary contents of the specified register. This is the READ/WRITE register. Values are typically 32 bits wide (4 bytes) and contain a single IEEE754 floating-point value. Modbus registers are 16 bits wide (2 bytes), so a minimum of 2 Modbus registers are required to transfer all floating-point bits to the master. See the section titled Floating Point Format.

Query

The query message specifies the starting register address and the quantity of registers to be read.

0x03 READ MULTIPLE HOLDING REGISTERS or
0x04 READ MULTIPLE INPUT REGISTERS

-QUERY-	-RESPONSE-
SA – SLAVE ADDRESS	SA
04 – FUNC CODE	04
RH – REG ADDR HI	BC – # of data bytes to follow
RL – REG ADDR LO	DATA0
00 – # OF REGS HI	DATA1
CT – # OF REGS LO	DATAn
CH – CRC MSB	CH CRC MSB
CL – CRC LSB	CL CRC LSB

REG ADDR HI (RH) is set to:

- 01 for INTEGER access of integral values
- 02 for IEEE754 floating point
- 03 for Scaled (x1000) long integer of the floating-point value

REG ADDR LO (RL) is the starting address index into the register structure. See the section titled [Sage Register Index Values](#).

CT is the register count needed to transfer data. Typically, this byte is set to 02 to request 1 full

IEEE754 floating-point value. (Modbus single registers are 16 bits wide, Sage floating-point values are 32 bits wide.)

DATA0-DATAn are bytes in the binary format returned from the slave device representing the selected register(s) contents.

NOTE: Values indicated with 0x prefix are in hexadecimal, otherwise in decimal notation.

16 (0x10) Write Registers

Writes the binary contents of the specified register into the meter. Values are typically 32 bits wide

(4 bytes) and contain a single IEEE754 floating-point value. Modbus registers are 16 bits wide (2 bytes), so a minimum of 2 Modbus registers are required to transfer all floating-point bits into the meter. See the section titled Floating Point Format.

Query

The query message specifies the starting register address and the quantity of registers to be written.

16 (0x10) WRITE MULTIPLE REGISTERS

–QUERY–	–RESPONSE–
SA – SLAVE ADDRESS	SA
0x10 – FUNC CODE	0x10 – 16 FUNC CODE
RH – REG ADDR HI	RH – REG ADDR HI
RL – REG ADDR LO	RL – REG ADDR LO
00 – # OF REGS HI	00 – # REGS HI
CT – # OF REGS LO	CT – # REGS LO
BC – BYTES COUNT	CH – CRC MSB
DATA0	CL – CRC LSB
DATA1	
DATA _n	
CH – CRC MSB	
CL – CRC LSB	

REG ADDR HI (RH) is set to:

- 01 for INTEGER access of integral values
- 02 for IEEE754 floating point
- 03 for Scaled (x1000) long integer of the floating-point value

REG ADDR LO (RL) is the starting address index into the register structure. See the section titled Sage Register Index Values.

CT is the register count needed to transfer data. Typically, this byte is set to 02 to request 1 full IEEE754 floating-point value.

BC is the actual number of bytes that follow.

DATA0-DATA_n are bytes in binary format transmitted to the slave device representing the selected register(s) contents.

Sage Register Index Values

DATA TYPE	VALUE	SIZE	INDEX	ADDRESS DESCRIPTION
Byte	slave_ad	1 BYTE	1	Modbus Slave Address*
float	flow_rate;	1 IEEE754	578	actual flow rate
float	flow_temp;	1 IEEE754	580	process temperature
float	rtd_mWatts;	1 IEEE754	582	sensor power reading
float	rtd_res;	1 IEEE754	584	actual sensor probe resistance
float	ref_res_r;	1 IEEE754	586	actual temperature probe resistance
integ	totalizer;	1 uLONG	312	actual displayed total

0x06 – COUNT OF ALL DESIRED REGISTERS

0xD5 – CRC HI BYTE

0x85 – CRC LO BYTE

***NOTE: Sage Meters are factory programmed with the MODBUS slave address = 48 (0x30). It may be beneficial to write to an unknown slave address with a simple broadcast command. Be sure only one instrument is connected during any broadcast writes using slave address = 0.**

Writing into unspecified registers (not defined above) can render the unit non-functional or overwrite factory calibration data yielding incorrect operation.

Example Modbus Packet

Query

This packet requests the addressed slave respond by sending back the contents of registers 578 to 582 (inclusive)—three registers: flow rate through RTD mWatts in IEEE754 floating-point format.

0x31 – SLAVE ADDRESS (0x31 Hex = 49 Decimal default)

0x04 – READ INPUT REGS FUNCTION CODE

0x02 – STARTING REGISTER HI BYTE (0x01 = 256, 0x02 = 512, 0x03 = 768)

0x42 – STARTING REGISTER LO BYTE (512 + 66 = register access = 578)

0x00 – COUNT MSB (ALWAYS ZERO)

Sage Register Output Format

Integer Representation

Computer systems hosting a MODBUS network typically store integer values to represent non-fractional quantities.

All registers addressed above 256 (0x0100-0x1FF) transfer 16-bit integral quantities in response to all master queries. MODBUS requires that the register count reflects each 16-bit registers transmitted to ensure that no bytes are missing in the transfer of integer quantities. (Note: Most registers are IEEE754 quantities; integer representations of these registers require significant translation.)

IEEE754 Floating Point

Computer systems hosting a MODBUS network typically store single-precision floating-point data in the standard IEEE754 format.

All registers addressed above 512 (0x0200-0x02FF) transfer full 32-bit single-precision quantities in response to all master queries. MODBUS requires that two 16-bit registers are transmitted to ensure that no bytes are missing in the transmission of 32-bit quantities.

Scaled Decimal Representation

Computer systems hosting a MODBUS network may choose to represent single-precision floating-point values as scaled long integers (32-bit

values). The Sage meter converts floating point registers to integral units by multiplying the value by 1000.

Ex. Floating point value 1234.567 converts to integral value 1234567

All registers addressed above 768 (0x0300-0x03FF) transfer full 32-bit scaled integer quantities in response to all master queries. MODBUS requires that two 16-bit registers are transmitted to ensure that no bytes are missing in the transmission of 32-bit quantities.

For more information on the MODBUS protocol, see: <http://www.modbus.org/tech.php>

SageCom Software

SageCom™ is a powerful, easy-to-use software program that permits testing, diagnostics, performance verification, and local configuration capabilities for Sage thermal mass flow meters. This new software permits the user to perform various diagnostic tests efficiently, reassuring that the Sage flow meter is executing according to original specifications. **When ordering, the user must include the Modbus option.**

Sage Technical Assistance

Visit sagemetering.com, then in the upper navigation menu, select [“Get Help”](#) > [“Customer Downloads”](#) > [“SageCom Installer Zip File.”](#)

Registers Viewable from SageCom “Print SMB Data”

MODBUS option and RS485 to USB cable needed to access SageCom.

SMB Printout
Serial# 212414

Units: NLPM ID: 0x33
rev. Sage Meter v1.03

7/2/2021
9:00:48 AM

Parameter	Decimal Data	Hex Format
Calib mW Val	104.3580	8550B74C
K-Factor	1.000000	7F000000
Temp Calib[A]	1.102191E+1	823059C0
Temp Calib[B]	9.583540E-1	7E7556B0
Temp Calib[C]	0.000000E+0	00000000
Temp Calib[D]	0.000000E+0	00000000
Flow Coeff[A]	-1.211378E+2	85F2468E
Flow Coeff[B]	2.685860E+0	802BE521
Flow Coeff[C]	-2.368446E-2	79C205EA
Flow Coeff[D]	1.035194E-4	7159188E
Flow Coeff[E]	-1.708183E-7	68B76A2D
Flow Coeff[F]	1.106495E-10	5D735222
Filtering	0.500000	7E000000
Min Flow/LFC	0.000000	00000000
Full Scale	1200.000	89160000
Min Temp	40.00000	84200000
Units/Pulse	100.0000	85480000
IDAC Min	802	00000322
IDAC Max	3996	00000F9C
Serial Number	212414	00033DBE
Flow Units	NLPM	4E4C504D
Tot/Tmp Units	NL [°C]	4E4C2043
Output Config	PULSE OUT	00000008
Pulse Dur mS	250	000000FA
Gas Type	AIR	00000000
STP Index	0°C and 1.013 Bar Abs.	00000000
TAG_1		00000000
TAG_2		00000000
Zero Flow mW	99	00000063
Max Flow mW	529	00000211
X section	0.000000	00000000
C-Factor	0.000000	00000000

SECTION G:

Appendix

Correction Factors for Variation from Original Digester Gas Calibration

Sage can calibrate for any Digester Gas, Bio Gas, or Landfill Gas Mix. However, it may be helpful to have correction factors for a typical calibration if the composition changes after delivery.

The following examples assume that the initial calibration was set up for 60% CH₄ and 40% CO₂.

- a) 65% CH₄ and 35% CO₂: Multiply reading by 0.982 to correct it for new composition
- b) 70% CH₄ and 30% CO₂: Multiply reading by 0.965 to correct it for new composition
- c) 55% CH₄ and 45% CO₂: Multiply reading by 1.0185 to correct it for new composition
[For smaller changes, the corrections are linear in between]
- d) Also, if 100% saturated with H₂O vapor (non-condensing), multiply readings by 1.042
- e) If 50% saturated with water, multiply the reading by 1.021
[Water vapor correction is linear in between]

Also, use the 45-degree mounting method to avoid droplets from hitting the sensor and causing spikes (see image above).

Installations Where Pipe Condensation May Develop

What is a Thermal Mass Flow Meter?

- What is a Thermal Mass Flow Meter? It is a meter that directly measures the gas mass flow based on conductive and convective heat transfer.
- All Meters have probes (Insertion Style) or Flow Bodies (In-Line Style) that support a pair of sensors in contact with the gas.
- The sensors are RTDs, which are resistance temperature detectors. They consist of highly stable reference-grade platinum windings. We use the same material that is used as Platinum Resistance Standards at the NIST.
- The RTDs are clad in a protective 316 SS sheath for industrial environments.
- One of the RTDs [See Diagram below] is self-heated by the circuitry and serves as the flow sensor. The other RTD acts as a reference sensor and measures the gas temperature. Essentially it is used for temperature compensation.
- The Sage proprietary hybrid-digital sensor drive circuitry maintains a constant overheat between the flow sensor and the reference sensor. As gas flows by the heated sensor (flow sensor), the molecules of flowing gas carry heat away from this sensor, and the sensor cools down as it loses energy. The circuit equilibrium is disturbed, and momentarily the temperature difference between the heated sensor and the reference sensor has changed. The circuit will automatically (within 1 second) replace this lost energy by heating the flow sensor, so the overheat temperature is restored.
- The current required to maintain this overheat represents the mass flow signal. There is no need for external temperature or pressure devices.

